

JULY/AUGUST 2016 • VOLUME 8, NUMBER 2

 **NaSPA**
Network and Systems Professionals Association

technical[®] *Supporting Enterprise Networks and Operating Environments* **SUPPORT**

Congratulations to NaSPA on 30 Years of Serving IT Professionals

By Scott Sherer, Founder

3D Printing Our Way to the Stars

By John Hornick

NaSPA Memories, This Time Back to 1996!

Contents

3 **Message from the President**

Feature Article

4 **Congratulations to NaSPA on 30 Years of Serving IT Professionals**

By Scott Sherer

Articles

7 **Using Analog Sensors with Raspberry Pi**

By Richard Blum

16 **3D Printing Our Way to the Stars**

By John Hornick

19 **Three Misconceptions about RAIDs**

By Mike Cobb

21 **Envisioning the Future of Moore’s Law, More than Moore & Beyond Moore for Global Semiconductor Industry - Part II**

By Apek Mulay



Join NaSPA now!

Call for Authors

Technical Support Magazine brings you an eclectic collection of articles, of interest to Information Technology professionals of all types. Do you have valuable insights and ideas that can be shared with NaSPA members? Fresh, timely ideas are important to our members, even if you have never published before. Our editorial staff is here to help and welcomes your submission. It’s never too late to start. Contact editor@NaSPA.online for more information or to submit your article for review for possible inclusion in a future edition of *Technical Support*.

The mission of NaSPA, a non-profit corporation, is to advance the technical management and career development abilities of its Members.

NaSPA fosters a greater respect for network, mainframe, information technology, telecommunications, business continuity, and other professions, while it improves employment prospects and educational opportunities for thousands of practitioners worldwide.

Inspiring advancement of technology professions since 1986.

The information and articles in this magazine have not been subjected to any formal testing by NaSPA, Inc. or Network and Systems Professionals Association. The implementation, use and/or selection of software, hardware, or procedures presented within this publication and the results obtained from such selection or implementation, is the responsibility of the reader.

Articles and information will be presented as technically correct as possible, to the best knowledge of the author and editors. If the reader intends to make use of any of the information presented in this publication, please verify and test any and all procedures selected. Technical inaccuracies may arise from printing errors, new developments in the industry and/or changes or enhancements to components, either

hardware or software.

The opinions expressed by the authors who contribute to *NaSPA Technical Support* are their own and do not necessarily reflect the official policy of NaSPA, Inc. Articles may be submitted by members of NaSPA, Inc. The articles should be within the scope of host-based, distributed platforms, network communications and data base, and should be a subject of interest to the members and based on the author’s experience. Please call or write for more information. Upon publication, all letters, stories and articles become the property of NaSPA, Inc. and may be distributed to, and used by, all of its members.

NaSPA, Inc. is a not-for-profit, independent corporation and is not owned in whole or in part by any manufacturer of software or hardware.

All corporate computing professionals are welcome to join NaSPA, Inc. For information on joining NaSPA and for membership rates, see www.NaSPA.com.

Notice: You have received this email because you are a member of NaSPA <http://www.NaSPA.com>, the Network and Systems Professionals Association, Inc., or a subscriber to *Technical Support* magazine. NaSPA believes this publication to be of value to you and your career. If you wish to opt-out and not receive this magazine in the future or would like to change your delivery address, please send an email with your request to editor@NaSPA.online

All product names and visual representations published in this magazine are the trademarks/registered trademarks of their respective manufacturers.

Message from the President



When All Else Fails

Despite the Internet, cell phones, email, text messages and other means of communications, whole geographic areas often find themselves out of service to a variety of disruptions. In cases like these, the one service that almost never fails is amateur or “ham” radio. Ham operators provide critical communications during unexpected emergencies across America including storms, wildfires, tornadoes, cable cuts, cyber attacks and more. Ham radio provides the most available and reliable communication in the first critical hours after a disaster. Since ham radio is not dependent on infrastructure like cell towers, it works when nothing else is available. It is truly a technology for “When All Else Fails.” There are 700,000 amateur radio licensees in the U.S. and 2.5 million worldwide, assisting emergency response agencies and helping out in many non-emergency events. All for free.

Many NaSPA members are Ham Radio Operators. NaSPA President **Leo A. Wrobel**, Technical Support Editor in Chief **Sharon M. Wrobel**, and NaSPA Founder **Scott Sherer** all hold “Amateur Extra” licenses. The “Extra” license is the highest class of license issued by the Federal Communications Commission for amateur radio operators. This gave us an idea.

NaSPA wishes to honor Amateur Radio Operators nationwide, and commemorate its 30th birthday with the first annual “NaSPA QSO Party.” Beginning on July 4, 2016, a NaSPA radio operator will be on the air, at random times and frequencies, taking check-ins. If we log a contact with you during our QSO Party we will send you a nice commemorative QSL card and a free Associate membership. If you are already a NaSPA Member, your next year is free. You also will get a chance to talk directly with Sharon, Leo, Scott or other NaSPA station operator. What fun! If the response is good we’ll make it an annual thing.

“See” you on the bands and 73!

Leo, Sharon and Scott



technical[®] Support

JULY/AUGUST 2016

Volume 8, Number

Published exclusively for NaSPA, Inc.
Network and Systems Professionals Association

www.NaSPA.com

NaSPA Board of Advisors

Chairman	Leo A. Wrobel
Secretary	Sharon M. Wrobel
Treasurer	David P. Mowery
Chairman Emeritus	Scott Sherer
Advisors	Sharon M. Wrobel David P. Mowery Bill Elder

e-mail addresses available on www.NaSPA.com

Technical Support™ Magazine

Editor-in-Chief	Sharon M. Wrobel sharon@NaSPA.com
Associate Editors	Jim Justen jmjusten@NaSPA.com
Graphic Designer	Michelle Lipa michelle@NaSPA.com
List Rental and Website	Sheila Kwiatek sheila@NaSPA.com
Advertising Sales	(888) 215-0997

Notice: You have received this magazine because you are a member of NaSPA, the Network and Systems Professionals Association, Inc., or you are a NaSPA subscriber. NaSPA believes this publication to be of value to you and your career. If you wish to opt-out and not receive this magazine in the future or would like to change your delivery address, please send an email with your request to editor@naspa.online

©2016 NaSPA. All Rights Reserved.

 **NaSPA**
Network and Systems Professionals Association

Congratulations to NaSPA on 30 Years of Serving IT Professionals

By Scott Sherer, Founder

It's so hard to believe that NaSPA is celebrating its 30th birthday. Or is it anniversary? According to Meriam-Webster *birthday* and *anniversary* are synonyms, so I guess it doesn't really matter. How NaSPA started might be worthy of a bit of reminiscing so maybe I'll dwell on that for a moment or two. I think I'm allowed to do this once every thirty years or so. If you're reading this, thanks for this moment.

Back in 1985 I was Technical Services Manager for then Bucyrus-Erie Corporation in Milwaukee, Wisconsin. I had been in that position for about ten years or so and we had a pair of IBM 3033 mainframes running MVS for an operating system, VTAM for telecommunications and IMS and CICS for database and transaction handling. Back in those days the data center was about 5,000 square feet. We had computer operators hanging tapes, loading continuous form paper in high-speed (for the day) printers and answering questions on the console. We had about 30 gigabytes of disk space and 16 megs of main storage, which we still called *Core* even though it was solid state. Our CPU was water cooled and required 400 hertz to operate, which was supplied from a giant motor-generator. The floor was elevated because the cables interconnecting everything were two inches in diameter and it took a foot of space to run them all.

At the time it was very exciting. We didn't call it IT then. First, it was *tabulating* and we used punch cards and cabled patch boards for programming. Then it was *data processing* when our first Fortran, Cobol and Assembler computers came along. These boxes had 16k (that's k, as in kilo, or 1,000 bytes) of memory. When IBM System 360 came along it we renamed our computer departments again. Now it was *Management Information Systems*, or *MIS* for short. We loved this abbreviation because we

named our Standards and Policy Manual *MIS-Info*. All of our computer personnel loved the name but outside of our department it wasn't so popular. Needless to say, it didn't last long. After a while the letter M was dropped and it just be IS or Information Systems. Back around the end of the 1990's it was changed to *IT*, or *Information Technology* for reasons that I don't know and that has stuck ever since. We can only hope that this name sticks for a while.

Our Operating System names changed a lot, too. Back when I started there were no operating systems. You booted from a deck of cards or a tape. We had things like 1401 Autocoder, 7044, 7074, etc. No multi-tasking or multi-programming back then. In fact, disk files, or data sets as we called them then didn't have a label stored on disk. You had to remember what cylinders were used. There was no operating system protection of these files. It really didn't work out too well, as you can imagine. Then we got to System 360, designed by the late, great Gene Amdahl of IBM. What a brilliant inventor he was. Unfortunately, his invention, System 360, caused more divorces than any other profession as it came to age in the 1960's. When we got to System 370, in, you guessed it, the 1970's, database processing came out.

Back around the end of the 1990's it was changed to IT, or Information Technology for reasons that I don't know and that has stuck ever since.

Our operating system, MVS and our database, IMS were an unbeatable pair and built corporate America. Many

of these applications, written mostly in Cobol are still running today.

Enter the 1980's, the age of PC's and Novell NetWare. The IT folks just laughed at the little toys called PC's. Running quaint DOS and applications coded in BASIC. We all laughed and turned our noses. We were much more concerned with the DEC VAX 11/780's and their variants. They ran Ethernet and we had coax and twisted pair.

It took about ten years for IT to get serious about the PC revolution and it happened about the time that Microsoft invented Windows 95 and went head to head with IBM's OS2. Windows cleaned IBM's clock and it became a Windows world. Even the IBM mainframes were forced to embrace the PC revolution. In the corporate world all of the dumb 3270-style CRT terminals were replaced with PC's on the front end. IBM had invented the PC and soon lost control of it. Microsoft took over DOS from IBM and developed Windows. Ethernet and TCP/IP were the topologies and protocol of choice replacing the point-to-point SDLC and Binary-Synchronous mainframe protocol.

After a while IBM announced a Unix-variant that would run on the mainframe and start to compete with PC-based servers. For the big corporate world you could now partition a large mainframe into both a web server and the old legacy Cobol apps. They found a way to unite the mainframe with the new PC technology and it worked really well.

Back in the day we had about 12,000 datacenters in the US running mainframes. Now we have a couple of thousand unbelievably large mainframes running what we like to lovingly call *The Cloud* now competing with hundreds of thousands of small to medium sized businesses running PC servers on cards and in large clusters. Both architectures run well together and compatibly in a world networked environment named by Al Gore as the Internet or National Data Super Highway.

Our members have changed over the years, too. The hardware used to be all made by IBM and so it always worked compatibly. The operating system, database manager, compilers and assemblers and transaction

handlers were also made by IBM so they always worked well together, too. In the PC workstation and server environment you can have a box with hardware made by ten different manufacturers and a similar mix with the software. It has taken about 30 years of PC evolution to get all of the standards in place so that it all works together. All of this even works well with compatible Apple Macintosh products, not to mention all of the portable tablets, phones and PDA's and the Internet of Things.

Clearly we live in an exciting time with all of this technology and it is our members that make it all work. Long ago one of our members, a chapter president from Denver, Colorado named Emit Hurdelbrink, who later went on to become NaSPA Board of Directors Chairman posed a question to me over a drink at a NaSPA Convention in Orlando, Florida in the mid-1990's. He said, "I've been thinking Scott, what if all of NaSPA's members called in sick one day?" We looked at each other in silence. We knew the answer. The world would stop.

I'm very proud to have created NaSPA. Over the decades our members have built corporate America into the world computing powerhouse that it is. Even more important, however, is that it's still our members that make the world go round. Great work to all of you, I wish you another great 30 years!

ABOUT THE AUTHOR

NaSPA Member, Scott Sherer is the founder of NaSPA. Mr. Sherer started his career as a Systems Programmer in Chicago, Illinois, in the early 1970's after getting a Bachelor's Degree from Southern Illinois University in 1973. He attained the position of Technical Services Manager at Bucyrus-Erie in Milwaukee, Wisconsin, in 1977, a position that he held for ten years until starting NaSPA in a bar in 1986. Under Mr. Sherer's direction, NaSPA achieved 50,000 members in 110 countries around the world.



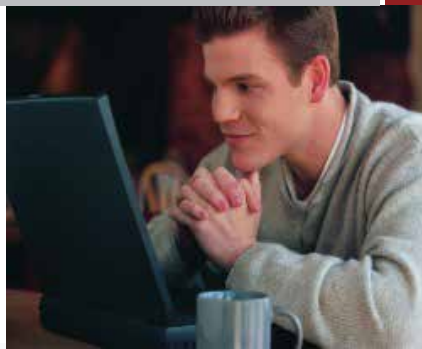

The Perfect Employer or Employee is Just a Click Away!

Job Seekers

- Convenient One-Stop Format
- Manage Your Job Search
- *Thousands* of Job Postings
- Post an Anonymous Resume
- Arrange Email Job Alerts
- Nationwide Exposure!
- Search by State or Job Title
- Much More - All FREE

Employers

- Convenient One-Stop Format
- Quickly Post Job Openings
- Reach Qualified IT Candidates
- Manage IT Recruiting Efforts
- Really, *Really* Inexpensive!
- Save Recruiting Fees
- Combine with Magazine or Web Site Ads *Inexpensively*
- From Only \$190.00!

**Recruit Qualified Professionals
or Find Your Next Job on the**



NaSPA

Network and Systems Professionals Association

Job Site

careers.NaSPA.com

Using Analog Sensors with the Raspberry Pi

By Richard Blum

Richard Blum, co-author of Sams Teach Yourself Python Programming for Raspberry Pi in 24 Hours, Second Edition, walks through how to use analog sensors to capture data with your Raspberry Pi.

The Raspberry Pi and Sensors

The Raspberry Pi has quickly become a popular platform for Linux hobbyists as well as professional developers. Its small size and versatility have made it a favorite for developers to use in small devices that require Linux support. The Raspberry Pi's General Purpose Input/Output (GPIO) interface provides a digital interface for easy control of motors, activating switches, or monitoring digital sensors. Unfortunately, though, the GPIO interface doesn't support analog inputs.

With the popularity of hobbyist microcontrollers such as the Arduino and BeagleBone devices, analog sensors for monitoring such data as temperature, humidity, light, and even wind speed are readily available. With the addition of a single integrated circuit (IC) chip, you can interface any type of analog sensor with your Raspberry Pi.

This article explains how to use the common MCP3008 analog-to-digital converter (ADC) chip to convert any type of analog signal to a digital signal that your Raspberry Pi can process. I'll demonstrate this process using a TMP36 temperature sensor, including creating a web page you can use to display the current temperature from anywhere on your network.

Background Info: The Serial Peripheral Interface

The Raspberry Pi GPIO interface primarily supports digital input and output signals, and it supports two popular digital communications standards:

- The Serial Peripheral Interface (SPI) standard provides a way for digital devices to share data serially.
- The Inter-integrated Circuit (I2C) standard was developed to attach peripheral ICs to microcontrollers.

You can use either of these protocols from the Raspberry Pi to communicate with external devices.

For this example, we'll use the SPI feature in the Raspberry Pi GPIO interface to communicate with an MCP3008 IC chip to retrieve data from the analog-to-digital converter. This setup allows you to connect up to eight analog sensors to the chip, using a Python program to read the data from those sensors, using the SPI protocol.

The SPI protocol requires four wires to connect between the GPIO interface and the MCP3008:

- SCLK: Serial clock
- MOSI: Master out, slave in
- MISO: Master in, slave out
- SS: Slave select

Because the SPI standard uses a bus architecture for communication, you can connect multiple SPI receiving devices to the same bus, as shown in Figure 1.

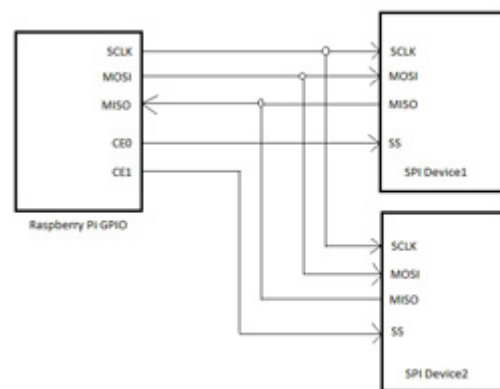

Figure 1 Connecting the Raspberry Pi GPIO to multiple devices using SPI

The SPI host enables each individual receiving device by activating the slave select (SS) line connected to that device.

Enabling SPI on the Raspberry Pi

Before you can communicate with SPI on the Raspberry Pi, you must enable the SPI device in Linux, and load the software driver (called a module) into the Linux kernel. To enable the SPI device, you can use the `raspi-config` utility. From the Raspbian command line, just enter the following command:

```
sudo raspi-config
```

In the raspi-config menu, select the Advanced Options menu entry, and then select the option to enable the SPI interface. When prompted whether you want to load the SPI module at boot time as well, select Yes, and then exit the raspi-config menu. After rebooting your Raspberry Pi, you can check for the SPI devices in the /dev folder:

```
ls -l /dev/spi*
```

To be able to use the SPI device to communicate with the MCP3008 sensor, you'll need to load the spidev library into your Python libraries. The next section provides the details.

Using the spidev Library

To get your Python programs to communicate with SPI devices, you'll need a special library of functions. The spidev library was developed to provide a software interface to the SPI device on the Raspberry Pi. Unfortunately, that library is not installed by default in the Raspberry Pi Python library, so you'll need to add it. You can download the spidev code from the GitHub repository website and then compile it into your Raspberry Pi library with just a few simple commands:

```
sudo apt-get install python3-dev
wget https://github.com/Gadgetoid/
  py-spidev/archive/master.zip
unzip master.zip
rm master.zip
cd py-spidev-master
sudo python3 setup.py install
```

The python3-dev library provides the development environment for your Python library. The wget command retrieves the current spidev code from GitHub, and then the setup.py script installs it into your Python3 library. (If you're using Python2 instead, just use python instead of python3 in the command.)

Now that you have the SPI device and your Python SPI library set up, you're ready to start building a project. For this project, we'll connect a TMP36 analog temperature sensor to the MCP3008 to monitor the temperature. We'll use a web page to display the current temperature, and then any device on your local network can access the web page and the temperature data.

Installing a Web Server

To communicate remotely with the Raspberry Pi to see the temperature, we'll use a standard web server. Several web server packages are available in the Raspbian software

repository; we'll use the standard Apache web server. To install it, enter this command:

```
sudo apt-get install apache2
```

That's all you need to do. The Apache web server is installed and activated automatically. You can test it by opening a browser (either using the graphical desktop on your Raspberry Pi, or from another workstation on your local network), and then connecting to the IP address assigned to your Raspberry Pi. My network used the following URL:

```
http://192.168.1.77
```

To allow your web programs running on the Apache web server to talk to the SPI devices, you'll need to give the user account that runs the Apache web server permissions for the SPI devices. Enter this command:

```
sudo usermod -a -G spi www-data
```

This instruction adds the www-data user account to the spi group on the system.

Now you're ready to build the electronics for the project. The next section covers how it works.

Building the Project

To connect the MCP3008 ADC and TMP36 temperature sensor to the Raspberry Pi GPIO, you'll most likely want to use a breadboard. The Pi Cobbler provides a ribbon cable and breakout device that allow you to plug into the GPIO interface and access the ports on a breadboard easily. After plugging in the Pi Cobbler breakout device, the MCP3008 chip, and the TMP36 device in separate locations on your breadboard, wire up by following this chart:

```
GPIO Pin????? MCP3008 Pin
?1???????????? 15,16? (Vref and Vin (3.3V))
?5? ???????????9,14?? (GND)
19? ???????????11???? (Pi MOSI -> MCP3008 Din)
21? ???????????12???? (Pi MISO -> MCP3008
  Dout)
23? ???????????13???? (Pi SCLK -> MCP3008
  CLK) (clocks)
24? ???????????10???? (Pi CE0 -> MCP3008
  CS) (chip select)
```

For the TMP36 device, connect pin 1 (Vin) to the 3.3V power bus, pin 3 (GND) to the ground bus, and pin 2 (Vout) to pin 1 (Channel 0) on the MCP3008.

In addition to these connections, place a 0.01uF capacitor across TMP36 pins 2 and 3 to help stabilize the output from the sensor. Without the capacitor, the output can be somewhat erratic, and is prone to be wrong. Figure 2 shows the basic connections.

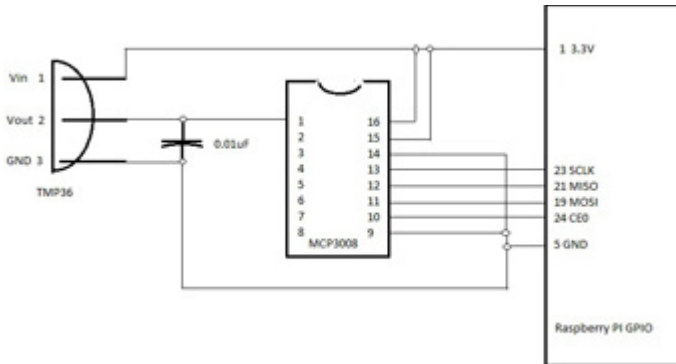

Figure 2 Wiring the MCP3008, TMP36, and capacitor to the GPIO interface

Writing the Code

Now you're ready to code the project. In your Home folder, open an editor and enter this code:

```
#!/usr/bin/python3
import spidev
spi = SpiDev()
spi.open(0,0)
channel = 0
vRef = 3300
result = spi.xfer2([1, (8 + channel) << 4, 0])
adcValue = ((result[1] & 3) << 8) + result[2]
mVolts = round((adcValue * (vRef / 1024.0)),2)
tempC = round(((mVolts - 500) / 10.0), 2)
tempF = round((tempC * (9.0/5.0) + 32.0), 2)
print('Content-Type: text/html')
print("")
print('<html>')
print('<head>')
print('<title>Temperature Sensor</title>')
print('</head>')
print('<body>')
print('<h2>Current Temperature Sensor Info</h2>')
print('The ADC value is:', data, '<br />')
print('The voltage is:', mVolts,'millivolts<br />')
print('The temperature is:',tempC,'degrees C<br />')
print('The temperature is:',tempF,'degrees F')
print('</body>')
print('</html>')
spi.close()
```

Save the text file as gettemp.cgi in your Home folder.

The spidev library uses the SpiDev() method to communicate with the SPI device on the Raspberry Pi. The open() method enables communication, and the xfer2() method both sends and receives a message with the SPI device. The trick is in telling the MCP3008 that you want to take a sample reading, and then reading that value from the MCP3008. According to the MCP3008 specifications, to activate a reading the MCP must receive a three-byte message:

```
00000001 1ddd0000 xxxxxxxx
```

The first byte must be a 1, and the second byte uses three bits to indicate which channel to read. For channel 0, we'll use the value 10000000. The value of the last byte doesn't matter.

When the MCP3008 chip receives the command, it takes a sample reading from the designated analog channel, and converts the analog value into a 10-bit digital value based on the relationship of the voltage to the reference voltage applied to the Vref pin (pin 15). The resulting 10-bit digital value is sent back to the requesting host as a three-byte value:

```
???????? ?????0bb bbbbbbbb
```

where bbbbbbbbbb is the 10-bit value.

So, to send the data to activate a reading, we use the following line:

```
result = spi.xfer2([1, (8 + channel) << 4, 0])
```

This command sends three byte values down the communication line. The first byte is the 1 value. The second byte sets the high bit to a 1, adds the channel value, and then shifts the four-bit value to the high part of the byte. Thus, for channel 0, we send the value 10000000, or 128. The third byte is irrelevant, so we just send a 0 value.

The xfer2() method waits for a response from the MCP3008, and returns the value as a list datatype:

```
adcValue = ((result[1] & 3) << 8) + result[2]
```

To retrieve the 10-bit value, we mask out the first two bits in the second byte value, shift it eight bits, and then add the value from the third byte. This technique returns a value between 0 (for 0 volts) and 1023 (for 3.3 volts), producing 1,024 possible values. To convert that digital value into the original millivolt analog value, we use this statement:

```
mVolts = round((adcValue * (vRef / 1024.0)),2)
```

The TMP36 sensor produces a 100mV output value at 40°C, and a 2000mV output value at 150°C. Using the equation found in the TMP36 data sheet, we can convert the millivolt output value into a temperature in Celsius:

```
tempC = round(((mVolts - 500) / 10.0), 2)
```

If you prefer, you can convert the Celsius temperature value to Fahrenheit by using the standard conversion equation shown in the code.

After you save the program code, you'll need to copy it into the Apache cgi-bin folder so you can run it as a web page, and then give the code permissions for the Apache web server to run it:

```
sudo cp gettemp.cgi /usr/lib/cgi-bin
sudo chmod +x /usr/lib/cgi-bin/gettemp.cgi
```

Now you're ready to test the setup.

Testing

Plug the Pi Cobbler ribbon cable into the GPIO interface. Then open a browser and go to the following URL:

```
http://localhost/cgi-bin/gettemp.cgi
```

Your temperature sensor data now appears on the web page!

Final Thoughts

Now you know how to get and use analog data on your digital device. With the power of the Raspberry Pi, you don't have to stop here. You can archive temperature data by storing the values in a MySQL database (using the Python MySQL connector), send them to an email address (using the Python SMTP methods), and so on. These features and much more are demonstrated in my book *Sams Teach Yourself Python Programming for Raspberry Pi in 24 Hours, Second Edition*.

ABOUT THE AUTHOR

*NaSPA Member, Richard Blum has been a network and systems administrator for over 10 years for a large government organization. He has had the opportunity to use Linux in a network environment as an e-mail server, FTP server, and network monitoring device for about 5 years. This experience has allowed him to gain an understanding of large email systems on the Internet. He also volunteers for a non-profit organization doing network administration. On this particular project, he has been involved with a team that designs and installs a local network file system and an Internet e-mail system for a small 30 user network. By working in both large and small network environments, he can relate to the problems of most network administrators in the field. He has authored two other books - *Sendmail for Linux* and *Running qmail from Sams*.*

© 2016 Pearson Education, Informit. All rights reserved.
800 East 96th Street, Indianapolis, Indiana 46240

This Sample Chapter is provided courtesy of NaSPA Supporter Pearson Publishing (Informit). Did you know NaSPA Members get 30% off Pearson/Cisco Press? See More Here!

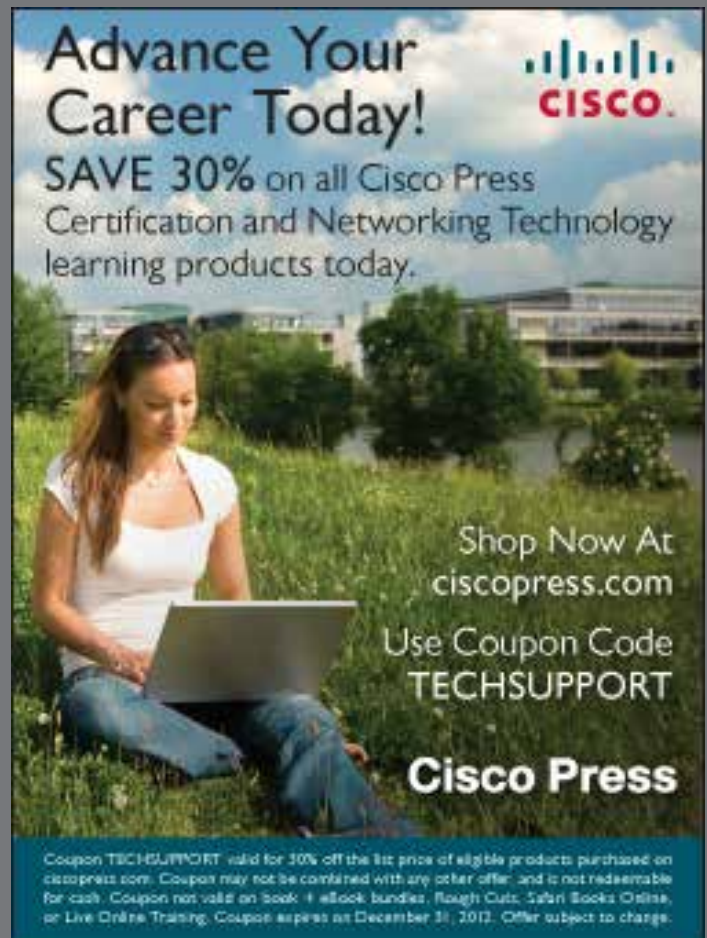

Advance Your Career Today!

SAVE 30% on all Cisco Press Certification and Networking Technology learning products today.

Shop Now At ciscopress.com

Use Coupon Code **TECHSUPPORT**

Cisco Press

Coupon TECHSUPPORT valid for 30% off the list price of eligible products purchased on ciscopress.com. Coupon may not be combined with any other offer and is not redeemable for cash. Coupon not valid on book + eBook bundles, Rough Cuts, Safari Books Online, or Live Online Training. Coupon expires on December 31, 2012. Offer subject to change.



OpenLegacy API Integration Platform 3.0 Accelerates Enterprise Digital Adoption

Provides lifecycle management, security, and control for APIs across the organization

Princeton, NJ, May 26, 2016 – OpenLegacy, the API integration platform provider, announces the availability of Version 3.0, containing new features that enable enterprises to extend and connect any backend system to digital consumers.

The API management console delivers the ability to control and manage APIs across the entire enterprise. Instead of managing API by API, OpenLegacy's newly released 3.0 allows administrators to manage the API lifecycle including analytics, versioning, caching, security and operations of each API to further increase system efficiency.

"Enterprises can now approach legacy system extension and connection from a strategic level, delivering customer-focused results," said Hans Otharsson, Chief Operations Officer, OpenLegacy. "Our customers have already been using our platform in clever and innovative ways and now can further expand on the flexibility and power of an API integration strategy in lieu of other, more time consuming and complex integration approaches."

The new release provides enhanced enterprise solution capabilities for API management, security, deployment and performance. Instead of simply providing a solution for a specific technical problem - connecting back-end systems to new protocols, OpenLegacy now allows the ability to create complete business solutions out-of-the-box including everything needed to work within a customer's digital economy.

The new features include:

- The new Unified Management Console is now the primary location from which to control the operation of the OpenLegacy platform along with full API lifecycle management and API usage statistics.
- Additional security features greatly enhance and improve the control over the back-end security far beyond what they previously had through authentication, access, data, and content control.
- Enhanced deployment and performance features including one-click deployment as secure APIs, workload balancing, deep caching, and scalable containers.

About OpenLegacy

OpenLegacy, named a 'Cool Vendor in Integration' by Gartner, has pioneered a unique compiled-API approach, instantly delivering enterprise core applications as digital services. OpenLegacy's non-intrusive solution is lean in time and resources and leverages years of investment in existing critical systems. OpenLegacy is revolutionizing the market by putting power into the hands of partners and customers. Together, they are extending the life and value of their enterprise systems, through the power of APIs. For more information, visit <http://openlegacy.com>.

Media Contact

Amy Kenigsberg
K2 Global Communications
amy@k2-gc.com
www.k2-gc.com
Tel: +972-9-794-1681 (+2 GMT)
Mobile: +972-524-761-341
U.S.: +1-913-440-4072 (+7 ET)

VitalSource Continues to Improve the Learning Experience with New Enhancements

VitalSource and Clever Collaborate to Provide One-Click Access to Materials for K-12 Students.

Nashville, Tenn. – June 1, 2016 – VitalSource, Ingram Content Group's educational technology division, and Clever are collaborating to reinforce security and convenience for K-12 users of VitalSource's digital content delivery platform, Bookshelf®. VitalSource is incorporating technology from Clever to create seamless and secure data integration between Bookshelf and a K-12 school's or district's student information system (SIS), all with single sign-on access.

"Growing our services for K-12 schools and districts and making it easy for them to streamline their processes is important for VitalSource," said Pep Carrera, VitalSource's COO. "We've worked with Clever to enrich services for K-12 users by providing secure delivery of digital learning content with single sign on to our Bookshelf platform for students and teachers."

Enhancements to the VitalSource Bookshelf platform allow schools and districts to focus on curriculum development while providing the technology to access and deliver the content. Schools and districts can easily ensure that student enrollment records, staff accounts and class rosters are integrated and updated automatically. Plus, students can access the VitalSource Bookshelf platform with one click from a secure portal.

"Partnering with exciting and innovative companies like VitalSource that empower teachers and enhance learning is Clever's goal," said Dan Carroll, chief product officer and co-founder of Clever. "Today, Clever is used by more than a third of K-12 schools in America. Together with VitalSource, we can extend the reach of our platforms and improve learning outcomes in even more schools across the country."

VitalSource's seamless integration with existing systems via Clever creates a user-friendly interface that gives teachers a way to share instructional resources, assignments, activities, and assessments with students and parents via personalized dashboards. Students will not need to enter any information to have VitalSource accounts and use mobile and desktop editions of Bookshelf.

About VitalSource

VitalSource Technologies Inc., part of Ingram Content Group, is a leading educational technology company and the preferred choice among higher education institutions, faculty and publishers. VitalSource has delivered compelling digital content to more than 12 million students in 200 countries and territories worldwide, and we have more than one million titles available in distribution from more than 750 education publishers. For more information about VitalSource, visit www.vitalsource.com

About Clever

VitalSource Technologies Inc., part of Ingram Content Group, is a leading Clever is the platform that powers the classrooms of tomorrow. Founded in 2012 by educators and technologists who knew that widely available educational apps could improve both teaching and learning, but that tools to deploy and secure the applications were simply unavailable. Today, one in three innovative K-12 schools in the U.S. trust Clever to secure their student data as they adopt learning apps in the classroom. In 2014, Clever won the 'Crystal Clear' award by the Digital Innovation Learning Awards. It is also the trusted provider of the American Federation of Teachers, who uses Clever to secure its own 'Share my Lesson' platform with its teacher members. Backed by Sequoia Capital, Lightspeed Partners, Peter Thiel's Founders Fund, and GSV Capital, Clever currently has 100 employees and is based in San Francisco, California. For more information visit www.clever.com

Contact: Elizabeth Fielding 615-321-3110
elizabeth@tsnashville.com

SNEAK PREVIEW OF JOB POSTINGS

Members! Here is Your Special “Sneak Preview” of Upcoming New Jobs, posting soon on the NaSPA Job Site

The following is a sample of the awesome jobs posted by employers in just the last 30 days on the NaSPA Job Site. NaSPA sincerely appreciates all the people who think of NaSPA first when they are looking for the ideal Information Technology candidate. They find the best people, and help NaSPA at the same time. These jobs have not hit our site yet so now you can have a “sneak preview” ahead of other applicants by Site right now and see what else is new!

Job Name Member of Technical Staff, Quality Engineering
Position Title Member of Technical Staff, Quality Engineering
Location(s) San Francisco, California, United States
Description

Salesforce.com Inc. seeks Member of Technical Staff, Quality Engineering in San Francisco, CA. Perform functional manual and/or automated testing if features, including writing detailed testing plans/relevant test cases to cover business use cases, error handling and boundary conditions as defined in tech specifications. Utilize internal tools to log/track product defects/verify fixes/ensure features impacted by the code change are regression tested. Estimate and prioritize work for optimal risk mitigation. Reqs: MS in CS, MIS, CE or related field (or foreign equivalent), + 1 yr exp in job offered or software developer/software engineer/software intern or related occupation OR BS in CS, MIS, CE or related field + 5 yrs exp in job offered or software developer/engineer/software intern or related occupation. Skills req: in depth exp/knowledge in: Java; testing process; automation testing frameworks; Unix; Eclipse; extensible markup language (XML); XPath. Any suitable combination of education, training, or exp acceptable. Employer will conduct background, education, exp, and criminal checks. Salary: \$122,000. 40 hrs/week, 9 am/5 pm/M-F. Send CV to: Recruitment and Employment Office, SALESFORCE.COM, Attn: Job Ref #: SAL76996, P.O. Box 56625, Atlanta, GA 30343

Job Name SOFTWARE ENGINEER
Position Title SOFTWARE ENGINEER
Location(s) Mountain View, California, United States
Description

Laserlike, Inc. in Mountain View, CA seeks Software Engineer to complete the following job duties:(1) Process a large amount of internet scale data, including web pages, news, social feeds, and other private data sources; (2) Implement high performance real time predictive analytics systems;

(3) System design, implementation, documentation, testing and tuning of the systems; and (4) Build systems taking into account all industry best practices for security and privacy.

Education requirements: Masters degree in Computer Science. 3 years of experience in a Software Engineer Occupation. Special skills required: 3 years of experience in the following: (1) Machine learning, applied to information retrieval problems; (2) Mining large data sets; and (3) Information extraction and ranking from web data.

Worksite Location: 888 Villa St, Suite 200, Mountain View, CA 94041.
Multiple Positions Available. Resumes can be sent to: jobs@laserlike.com.

Job Name Software Delivery Principal (AV-SDP-0516)
Position Title Software Delivery Principal
Location(s) Chicago, AND Various unanticipated locations throughout the U.S., United States
Description

ThoughtWorks Inc. seeks Software Delivery Principal to perform the following duties: Core member of the client services team responsible for the relationship with client; manage executive-level client

interactions and execute large scale, enterprise level complex programs of work encompassing multiple business and technical projects and initiatives; high-level management of all aspects of software delivery and consulting for multiple client accounts; use of broad enterprise-wide knowledge, understand business processes and technical knowledge to determine the client's strategic business needs; lead several project managers, consultants, subcontractors and partners to monitor on-going project delivery; develop strategic C-level relationships; create program and project proposals designed to benefit both parties in the development engagement; collaborate with specialty service areas within the business to solve client business problems; train, coach and mentor all members of project teams; work closely with the staffing function to ensure best fit of consultants to serve the client; set up enterprise program governance, reporting and active risk management; and track deliverables and dependencies across large complex programs of work. Willingness to travel at least 80% across the U.S.

Job Name Director of Engineering
Position Title Director of Engineering
Location(s) San Francisco, California, United States
Description

Director of Engineering (San Francisco, CA). Chute Corporation. Responsible for day-to-day management of the company's engineering team, which spans across web apps, mobile apps, API services, building effective organizations, scalable processes, to ensure company core products stay stable and scale indefinitely and new products delivered faster. Research new technologies, methodologies and tools to improve the company software development productivity. Experience in Ruby, Python, PHP, Java and Golang applications. Must have a Bachelors' Degree in Computer science or related and 5 years experience in related field. Please email resumes to lindsay@getchute.com

Job Name System Software Engineer
Position Title System Software Engineer
Location(s) Hayward, California, United States
Description

JBMICRO INC seeks System Software Engineer in Hayward, CA to build, scale, & secure data infrastructure on different operating environments. Combine open-source & commercial technologies to build sw applications. Produce sw applications that are scalable, automated, & well-documented. Install clusters & develop the architecture for a cluster mgmt tool. Determine application programming interface to interface w/ other sw sys components. Develop the automation modules for installing & configuring different sw framework distributions. Automate maintenance & upgrades across several hundred machines. Configure sw framework cluster & monitor integration to monitor sw framework clusters & alert integration. Coordinate modules for adding & removing data nodes. Position requires a Master's deg or foreign equivalent deg in Comp Sci, Comp Engg, Elec Engg, or rel field. Also requires coursework and/or experience in Comp Ntwrks, Adv Data Structures, Database Mgmt Sys, and SW Project Mgmt. Mon-Fri 40 hrs/wk. Wage \$124,218-\$129,808. Req 50% nat'l travel. Send resume to: Recruitment and Employment Office, JBMICRO INC, Attn: Job Ref #: JBM52028, P.O. Box 56625, Atlanta, GA 30343

Job Name Hadoop Data Integration Engineer
Position Title Hadoop Data Integration Engineer
Location(s) Hayward, California, United States
Description

JBMICRO INC seeks Hadoop Data Integration Engineer in Hayward, CA to review comp sys capabilities, wrkflw & limitations & collect data from various business units & implement code to sanitize data & improve comp sys. Architect, design, & maintain lrg-scale data integrat'n tools & processes. Design & implm't various statistical & visualiz'n tools to ctrl the quality of data. Load data & provide various data sets to analytical researches on a distrib'd data processing platform. Create & maintain relevant document'n. Evaluate & recomm'd method, sw tools, hrdwr configurat'n & sys configurat'n in support of integrated solutions.

Evaluate perform & capacity for implemented & planned solutions. Work w/ research & engineering teams to resolve support & technological solutions. Integrate big-data platforms w/ analytics. Work w/ big data tools for log data analysis. Utilize coursework and/or experience in Hadoop File System, Oracle Database, Hive, Hive queries, Sqoop, Data Mining, & Unix Operating System. Position req. Master's deg or foreign equiv deg in Comp Sci, Comp Engg, Elec Engg, or related field. Mon-Fri 40 hrs/wk. Wage \$76,877-\$86,877. Req. 50% nat'l travel. Send resume to: Recruitment and Employment Office, JBMICRO INC, Attn: Job Ref #: JBM64263, P.O. Box 56625, Atlanta, GA 30343

Job Name Systems Analyst
Position Title Systems Analyst
Location(s) Morrisville, North Carolina, United States
Description

Systems Analyst (Morrisville, NC and various unanticipated worksites throughout the US) (Multiple Positions)— Responsible for the development of system integrations, in terms of integration enhancements and/or resolutions to production problems as it relates to system integration. Translate integration designs into integration development solutions. Travel required to unanticipated locations throughout the US. Send resumes to: Recruitment, SunTechPros, Inc., 5920 S. Miami Blvd, Suite 205-B, Morrisville, NC 27560 or apply at www.suntechpros.com. Must reference Systems Analyst position.

Job Name Software Architects
Position Title Software Architects
Location(s) Jacksonville, Florida, United States
Description

Software Architects (Multiple Positions) req'd to provide techn. leadership in the design, dvlpmnt and dplymnt of s/w appls using at least three of the following tools and methodologies: MVC, SAP, VB.NET, ASP.Net, ADO.Net, MS Visual Studio, SQL Server, C#.Net, MS Visio & VSS. Wrk closely with programmers/dvlprs, QA and Biz Analysts, provide rpts to management and oversee creation of end-user support processes/documentation. Req: MS degree or equiv in Sci., Math, CS, IT, IS, Engg (Any) or rtd plus 2 yrs exp or in lieu, a BS degree or equiv in Sci., Math, CS, IT, IS, Engg (Any) or rtd plus 5 yrs progressive exp. Mail resumes to SGS Technologie LLC, ATTN: SA-JOBS, 6817 Southpoint Parkway, Suite 2104, Jacksonville FL 32216

Job Name Senior Database Developers
Position Title Senior Database Developers
Location(s) Rochester, New York, United States
Description

Senior Database Developers req'd to design, dvlp, test, extract, transf. & load (ETL) solutions for enterprise using Oracle Database Server, MS SQL Server (SSIS/SSRS), SQL (T/PL), VSS, SVN, JIRA. Facilitate Biz Int./OLTP solutions using SSRS, SSIS, Jasper Soft. Wrk closely w/ other dvlprs, architects and biz analysts in ETL program post prod. support. Req: MS degree or equiv in CS, Engg, IT, IS or a rtd. field plus 2 yrs exp. in DB dvlpmnt & testing, or in lieu, a BS degree or equiv in CS, Engg, IT, IS or rtd. field + 5 yrs of progressively exp. incl. 2 yrs exp in DB dvlpmnt & testing. Must be willing to travel/relocate to client sites anywhere in the U.S. No Telecommuting permitted. Mail resumes Attn: SSD-JOB to Netsmartz LLC, 332 Jefferson Rd, Rochester, NY 14623

Job Name Senior Software Developer
Position Title Senior Software Developer
Location(s) Rochester, New York, United States
Description

Senior Software Developers req'd to provide techn. leadership in the design, dvlpmnt of s/w appls using MS s/w dvlpmnt environments (such as Visual Studio) and C#, ASP.NET, SQL, Entity Framework, JQuery, REST/Web APIs, MVC, AJAX. Req: MS degree or equiv in CS/IT/IS/ Engg or rtd plus 2 yrs exp in s/w dvlpmnt & tstng in ASP.NET, C#, SQL, MVC, and JQuery, or in lieu, a BS degree or equiv in CS/IT/IS/Engg or rtd plus 5 yrs progressive exp., of which at least 2 yrs exp are in s/w dvlpmnt & tstng in ASP.NET, C#, SQL, MVC, and JQuery. Mail resumes Attn: SSD-JOB to Netsmartz LLC, 332 Jefferson Rd, Rochester, NY 14623

Job Name Hardware Development Engineer
Position Title Hardware Development Engineer
Location(s) Cupertino, California, United States
Description

Develop and ship the next generation of Human-Computer Interaction (HCI) hardware (e.g. mice, trackpads, keyboards, remotes, etc.). Work with cross-functional teams on the design, implementation, integration and qualification of Human Interface Devices. Responsible for schematic capture and managing printed circuit board layout design of the electrical system, including power management, micro-controller, wireless communication, sensor integration and component selection. Execute the design in high volume, including characterization and validation across all development builds. Authorize detailed engineering requirements specifications. Work with suppliers and manufacturing partners including overseas build support. REQUIREMENTS: Master's degree or foreign equivalent in Electrical Engineering or related field, and one year of experience in job offered or related Hardware Development occupation. Experience/Education must include: 1. Prototype, architecture, and design of Human Input Devices hardware: mouse, keyboard, trackpad, and remote; 2. Low power micro-controllers, such as MSP420, ARM, and Cortex-M3; 3. Prototyping and programming RTL on FPGA platform; 4. FW development on embedded system including real Time Operating System; 5. Engineering tools such as SPICE, Matlab, and Python; 6. Consumer-level wireless implementation such as Bluetooth and WiFi protocol; 7. Digital signal processing: Tools Matlab signal processing module; and 8. Travel required 25%. Work hours: M-F 9am-6pm, 40 hours/week. \$120,000-\$148,400/yr.

Submit resumes to: Recruitment and Employment Office, APPLE INC., Attn: Job Ref #: APP77489, PO Box 56625, Atlanta, GA 30343.

Apple is an EOE/AA m/f/disability/vets.

Job Name SAS Developer
Position Title SAS Developer
Location(s) Cary, North Carolina, United States
Description

FEATHER TECHNOLOGIES INC. has opening of SAS Developer: 40 hrs/wk, 9:00 A.M. to 6:00 P.M. (M-F), \$68,744.00 annually. Req: Masters in Computer Science, Engineering, Statistics or related & 1 year of experience, or Bachelors in Computer Science, Engineering, Statistics, or related & 5 years progressive of experience. Will accept alternative occupations: "SAS Programmer Analyst, SAS Programmer, or related." Develop SAS programs to generate tables, listings, figures & analysis datasets. Build SAS datasets for clinical database. Create SAS macros for data cleaning & reporting. Validate program datasets, document the programs, & develop study specific procedures. Create ad-hoc reports as per clinical study. Utilize SAS, SAS/STAT & SAS Macro language. Will work in unanticipated locations. Company location is in Cary, NC. There are 6 openings for this position. Will accept any suitable combination of education, experience, or training consistent with the requirements specified above. Submit resumes to: Recruitment and Employment Office, FEATHER TECHNOLOGIES INC, Attn: Job Ref #: FEA57066 P.O. Box 56625, Atlanta, GA 30343

Job Name Computer Professional
Position Title Computer Professional
Location(s) New Jersey, United States
Description

Computer Professional, Plainsboro, NJ & Other Client Locations (multiple openings): Involve in all phases of SDLC, analyze, design, develop, implement, configure, customize, & maintain applications & systems. BS/MS (BS + 5yrs Exp) in CS, MIS, CIS, Eng (any), or related in any one of the skill set: 1. C#, VB.Net, ASP.NET, T-SQL, Bootstrap, Java Script, Visual Studio, AJAX, JQuery, Oracle, MySQL, SQL Server, ASP, WCF, Silverlight, WPF, IIS, & Win. MS (BS = 5yrs exp) W/1yr exp & ref VRG1110-2016. 2. SQL, HTML, XML, UML, SQL Server, Access, Rational Requisite Pro, Share Point, Rational Clear Quest, Rational Clear Case, Quality Center, Test Director, MS Project, Outlook, PowerPoint, Visio, & RUP. MS (BS = 5yrs exp) W/1yr exp & ref GVR1100-2016. 3. Oracle BI Applications, Informatica, Oracle Discoverer, OBIEE, DAC, Weblogic, Oracle Applications modules Inventory, AP, AR, & Purchasing, Oracle Forms, Data Tracker, Net

Beans, C, C++, Java, SQL, PL/SQL, Unix & Win. MS (BS = 5yrs exp) W/1yr exp & ref PPR1020-2016. 4. Oracle, SQL Server, IMS DB, DB2, Clarity, JIRA, MS Project, SharePoint, Visio, VSS, CVS, Quality Center, Service Now, EQUIP, C#, ASP.NET, J2EE, Web Services, Visual C++, UA Framework, Web Sphere, Crystal Reports, Eclipse, Data Power, Java, Tenfold, VB Script, JavaScript, Agile, Waterfall, SOA, Design Patterns, Process Modeling, LEAN Thinking, Win, Linux, OS/2 & UNIX. BS/Equi (3Yrs college+2Yrs) W/2yrs exp & ref BNSR1050. 5. Network Eng: Technical supp, identify & res problem on Cisco & Non-Cisco supported prod. Resp for maintain entire network per SLA. Config, maintain & troubleshoot routers, switches & firewalls. Impl & config cisco security appliances, non-cisco Checkpoint, Fortinet, Juniper, & Websense. Update SAP CRM tool. Dev IT roadmaps for Network & Data security. Dsgn network secu & architect new projects. Impl firewall changes. Deploy VPN W/with others, IPsec, GRE. Perform AAA Administration, TACACS+, admin DNS Records, impl CISCO IDS/IPS, dsgn & depl internal & external security edges. Monitor changes to traffic patterns & perform threat analysis. Config & monitor F5 BIG-IP LTM & GTM. Duties entail working with Checkpoint firewalls, Cisco ASA firewalls, Juniper NetScreen, ScreenOS firewalls, Tufin Secure Track, F5 load balancers, Cisco ISE for NAC, Bluecoat Proxy for WAN optimization & Web security, Symantec DLP for data leakage prevention, Win, Linux, Unix, & Cisco Routers & Switches. MS (BS = 5yrs exp) W/1yr exp & ref PSR1090-2016. Mail resumes Smart IMS, 103 Morgan Ln, Plainsboro, NJ 08536 or email resumes@smartims.com.

Job Name MPH75354
Position Title Lead Systems Architect Developer-4
Location(s) New York, New York, United States
Description

Mphasis Corp. has five (5) openings for the following full time (M – F: 9AM to 6PM) prof position at its office in NY, NY & unanticipated client sites in the US.

Lead Sys Architect Devlp'r-4

Job Duties: Lead the effort in analyz'g user needs & SW reqs to det. feasibility of dsn & req for proposal of IT sol. Eval interface b/w HW & SW, dev architect. specifics & perform. reqs to improve IT ops. Lead a team of IT profs to dev detailed steps reqd to impl IT architect. sol for sys install & monitor sys. to ensure specifics are met. Rev validation proc. & qual stds. Must be able to travel temp to client sites and/or relocate thruout the U.S.

Job Reqs: Master deg or foreign eqv in CS, CA, CE, CIS, E'tronic Eng, E'trical Eng, Eng, or rel. studies + 2yrs of exp in job offered, PL, SW Eng, App devl'r or rel work. In the alt, we will accept Bachelor deg or foreign eqv + 5yrs of prog exp in job offered, PL, SW Eng, App devl'r, or rel work. We will accept experience in related job with similar job duties but given another designation or related occupation. Travel/relocation reqd.

Wages: \$130,666/yr with stand emp bene.

Submit resumes to:

Recruitment and Employment Office
 MPHASIS CORP, Attn: Job Ref #: MPH75354
 P.O. Box 56625
 Atlanta, GA 30343

Job Name Member Technical Staff, Software
Position Title Member Technical Staff, Software
Location(s) Waltham, Massachusetts, United States
Description

Opening available for Member Technical Staff, Software at NetApp, Inc. in Waltham, MA. Perform software engineering for data storage & network communication systems. Perform all aspects of data storage systems software design & development & collaborate with other software development & test engineers in the development & testing of storage operating systems. Participate in system software development projects for which analysis of situations & data requires a review of a variety of factors & technical skills in the area of UNIX/LINUX kernel programming. Requires master's or foreign equiv degree in computer science, computer engr, electrical engr, engineering or related tech field. Must have following skill set (evidenced by graduate level coursework or

prior experience): design & implementation of network communication &/or data storage systems software; TCP/IP networking; C/C++ programming; multithreaded programming; & scripting languages. Must pass company's tech review. Will accept any suitable combination of education, training, or experience which would qualify an applicant for the position. Fulltime (Mon-Fri, 9AM-5PM), salaried position. Salary range of \$120,000 to \$145,000 per year, DOE.

Medical, dental, & vision insurance plans & financial, savings, & worklife programs.

Applicants should mail résumés to Recruitment & Employment Office, NetApp, Inc., Attn: Job Ref# NET62987, P.O. Box 56625, Atlanta, GA 30343.

Job Name 49901
Position Title Sr. QA Engineer
Location(s) Raleigh, North Carolina, United States
Description

Sr. QA Engineer (Raleigh, NC) Creatively plan & execute test cases to certify that new devices and app updates meet rigid standards. Resumes to: Kellie Sigmon, HR, Bandwidth.com, 900 Main Campus Drive, 5th Floor, Raleigh, NC 27606 OR apply online at www.bandwidth.com.

Job Name Sr. Database Administrator
Position Title Sr. Database Administrator
Location(s) San Diego, California, United States
Description

Sr. Database Administrator at NUVASIVE, INC. Worksite: 7475 Lusk Blvd, San Diego, CA 92121. Administer/maintain databases/ network functions, incl. monitor, troubleshoot, configure, & document. Implement/conf. network infrastructure. On-call rotation to support 24x7 operations.

Job Name Deshmukh/ supervised
Position Title Programmer Analyst
Location(s) Matawan, New Jersey, United States
Description

Name of Employer: AIT Global Inc
 Address: 228 Route 34, Matawan, NJ 07747
 Offered Salary: \$83,741 per annum
 Job Schedule: Monday to Friday (Daytime Shift 9AM to 6PM)
 Seeking full-time qualified Programmer Analyst w/Bachelors or foreign equivalent in Comp. Sci. or CIS or Engineering & 2 years of related work experience as Systems Analyst or Software Developer to analyze, design, develop, test, maintain and update software systems in windows and UNIX platform using Java, J2EE Technologies, Servlets, XML, MOM/SOA architectures, Weblogic Web Services, Apache AXIS, Eclipse 3.x. Model View Controller Framework. Design/develop various infrastructure components for the web, middle-tier and for data access. Travel/Relocate may be required to unanticipated client site locations. Will accept 3 years or 4 years bachelor degree. Aspiring candidates should mail their resumes to:
 Recruitment and Employment Office
 AIT GLOBAL INC
 Attn: Job Ref #: AIT77802
 P.O. Box 56625
 Atlanta, GA 30343

Job Name Computer Systems Analyst V
Position Title Computer Systems Analyst V
Location(s) College Station, Texas, United States
Description

Cognizant Technology Solutions U.S. Corporation, Computer Systems Analyst V, pos located in College Station, TX. Develop, create, and/or modify software applications. Analyze user needs and develop software solutions. Analyze business and other data processing problems to implement and/ or improve software systems for assigned projects. Duties may include: expand or modify system to meet technical and business specifications; test, maintain, and monitor programs/ systems; support the installation/implementation of computer programs and systems; contribute to the development of documents; contribute to

enhancement of system design procedures, test procedures, and quality standards; support the creation of solutions to system challenges, such as malfunctions and system/ program problems; contribute to the review and analysis performance indicators to ascertain, develop, and implement improvements/ solutions; and coordinate and link systems to implement solutions across an organization. May oversee/ guide/mentor other professionals (depending on project or level of responsibility, may supervise 0-25 IT professionals). To perf duties, must have experience with one of the following technologies: Oracle, SQL, Core Java, Java, J2EE development, Microsoft web development with ASP, .NET, Network Development or Network Administration (excluding help desk and desktop support), Data Warehousing, Software Testing, SAP, Customer Relationship Management (CRM) software applications, and/ or Mainframe Development. May survey and observe users or perform the job to determine what information is processed and how it is processed. May support multiple projects of varied complexities. Engage in substantial long-term and/or short-term travel and/or relocation to unanticipated client locations throughout the U.S. to join established, operating onsite project teams with close, frequent supervision by a manager. 1,000+ Multiple full time positions available. 40 hrs/week M-F 9:00am – 5:30pm. MINIMUM REQUIREMENTS: Bachelor's degree or equivalent in Computer Science, Sciences, Engineering, Math or Business plus 60 months of experience in the job offered. Job duties require substantial long-term and/or short-term travel and/or relocation to unanticipated client locations throughout the U.S. for position based/reporting to College Station, TX. Certain travel and/or relocation expenses, and/or possible location-based pay, depending on assignment, paid by employer. Must have experience with one of the following technologies: Oracle, SQL, Core Java, Java, J2EE development, Microsoft web development with ASP, .NET, Network Development or Network Administration (excluding help desk and desktop support), Data Warehousing, Software Testing, SAP, Customer Relationship Management (CRM) software applications, and Mainframe Development. \$81,765/yr. Std. employee benefits. Submit resume to Recruitment and Employment Office, Cognizant Technology Solutions US Corporation, Attn: Job Ref #: COG72976, P.O. Box 56625, Atlanta, GA 30343.

Job Name RAN66765
Position Title Project Leader
Location(s) Tampa, Florida, United States

Description
 Rand Worldwide Subsidiary Inc., Project Leader, Tampa, FL. Project lead for new apps and enhancements built on salesforce.com platform. Program apps and integrate multi-systems using salesforce.com. Establish and maintain coding structure, documentation and database naming stds. Manage the sales.force.com CRM apps. Maintain functional areas of data mgmt, sales forecasting, contacts, leads, campaigns, opportunities, quotes, cases, dashboards and reports. Design bus. processes, rapid user interface configuration, user provisioning, data transfer and cleansing, report dashboard design, user training and documentation. Participate in cross functional teams and address strategic bus. issues involving CRM, services, marketing, support and sales ops. Act as a backup technical resource for Microsoft Dynamics GP, insight scribe architect and design specialist. 40 hrs/wk, Mon – Fri, 8:30am – 5:30 pm.

Requirements:
 Require at least 2 yrs of exp as an administrator or ERP/CRM Consultant / Partner or any combination thereof. Require a min. of 2 yrs of exp with salesforce.com, CRM applications, Microsoft SQL, Visualforce and APEX.

Salary: \$59,093 - \$90,000/yr; Comp. package includes std. company benefits.

Please apply to: Recruitment and Employment Office, Rand Worldwide Subsidiary Inc., Attn.: Job Ref #: RAN66765, P.O. Box 56625, Atlanta, GA, 30343.

Job Name APO70502
Position Title SW Developer II (Back/Front-End)
Location(s) Phoenix, Arizona, United States

Description
 Apollo Education Group, Inc. has an opening in Phoenix, AZ for a SW Developer II (Back/Front-End) Responsible for developing sw apps/services re: development & support of co.'s service platforms & marketing apps. Involved in developing sw apps for marketing users, services re: marketing business needs in collaborating w/ other teams & maintaining existing services & apps. Work w/ technical staff to understand & analyze moderately complex sw problems & develop, code, test & debug sw to resolve issues; & make suggestions/alternative resolutions for sw problems or enhancements & assist in development of user manuals to support ongoing use & application of sw + demonstrate sw to others to introduce them to new or enhanced apps, & provide direction & tech support to jr developers. REQUIRED: Masters degree in, or equiv. in computer engg (Will accept bachelors degree + 5 yrs exp. as equiv.). At least 6 months in position offered or in IT role incl. development. Skills: Front end, backend & database programming, incl. java framework development; production release & support; Java & Spring framework; REST & SOAP Webservices; Oracle, SQLServer, MySQL, NoSQL database technologies; Scrum methodologies; Eclipse; Putty; HTML/JavaScript/CSS; Cognos. Any suitable combination of education, training, and/or experience is acceptable. Schedule: 9:00 am – 6:00 pm M-F. Wage: \$92,000/yr. Submit resume to: Recruitment & Employment Office, APOLLO EDUCATION GROUP INC., Attn: Job Ref #:APO70502, P.O. Box 56625, Atlanta, GA 30343.

Job Name Sr. Data Warehouse Architect
Position Title Sr. Data Warehouse Architect
Location(s) Marietta, Georgia, United States

Description
 1Way Solutions, Inc. seeks Sr. Data Warehouse Architect to lead development of Data Warehouse & Business Intelligence solutions (8am-5pm, Mon-Fri) in Marietta, GA (Travel is not required but must be willing to relocate to unanticipated cities across the country per contract demand). Master's degree in Computer Science, Engineering or a related field plus 2 years of experience. In lieu of the above, we will accept a Bachelor's degree plus 5 years of progressively responsible post-baccalaureate experience. Foreign degree equivalent is acceptable. We will accept any suitable combination of education, training or experience. Experience to include Data Warehouse, Informatica and Hyperion. Offered Wage \$93,371/year with health insurance plan. Mail resume to U.S. DOL OFLC at: Recruitment and Employment Office, 1WAY SOLUTIONS, INC., Attn: Job Ref #: 1WA61024, P.O. Box 56625, Atlanta, GA 30343.



3D Printing Our Way to the Stars

By John Hornick

The Ultimate Space Exploration Machine

If Apollo 13 had a 3D printer (invented not too long after the event), the phrase “Houston, we have a problem” may not have entered the lexicon. Forty-four years later, NASA moved to prevent the use of that phrase by outfitting the International Space Station with a 3D printer in 2014. In a test with far-reaching implications for the future of space exploration, NASA, with the help of Made In Space Inc., essentially emailed the digital blueprint for a ratchet wrench from NASA’s Huntsville Operations Support Center to the space station, where it was 3D printed in plastic. The whole process, from conception, to design, to safety approval, to transmission, took less than a week, and the wrench was printed in about four hours, in zero gravity. According to Made In Space, the machine is capable of printing more than a third of the spare parts needed on the ISS.

NASA’s test highlights one of the great strengths of 3D printing: making things where and when they are needed. Another 3D printing strength is making complex parts that cannot be made in any other way. Another strength is making parts customized to the user’s needs. Another is making one-of-a-kind parts, instead of the one-of-a-million parts of mass production. Another is manufacturing simplification: a part, such as a fuel nozzle, that is assembled from 20 traditionally manufactured pieces, can be 3D printed as one part. For space exploration, 3D printers also help solve the problem and reduce the great expense of launching equipment and supplies into space and assuring that spare parts are there when needed. These strengths make 3D printers the ultimate space exploration machine.

Making Parts, Layer By Layer

Most people have heard of 3D printers but view them as simple machines that print out Yoda heads, layer by layer. Although Yoda is an apt symbol for 3D printing in space, 3D printing is so much more. One type of 3D printing

is called Material Extrusion, which is how both the space station’s ratchet wrench and Yoda heads are made. This process is relatively simple: extruding thermoplastics through a nozzle, for layered manufacturing. Other processes 3D print parts jetting layers of plastic or metal droplets, or by using lasers or electron beams to fuse layered parts from plastic or metal powders. NASA is testing another type of 3D printing process called Directed Energy Deposition, which uses an electron beam and metal wire to build parts in zero gravity. Lockheed Martin is using the same process to 3D print rocket fuel tanks from titanium wire. 3D printing the tanks is much faster than making them by the traditional method – casting– and costs half as much.

3D Printing is Rocket Science

Eventually the 3D printers in space will be able to print much more than plastic wrenches, just as they do now on Terra Firma. In 2013, NASA test fired a 3D printed fuel injector – the heart of the engine --for its Space Launch System, which will power the Orion spacecraft. The part was 3D printed by Aerojet Rocketdyne using a process called Powder Bed Fusion, where a laser melts metal powders layer by layer to build up a finished part. By 3D printing the part, rather than using traditional manufacturing methods, NASA reduced the production time from more than a year to only four months, with a 70% cost reduction. 3D printing also enabled the fuel injector’s design to be reduced from 160 pieces to just two.

In 2015, NASA used Powder Bed Fusion to 3D print a copper rocket combustion chamber liner designed to withstand high heat and pressure. By 3D printing the part, NASA integrated 200 complex cooling channels between the inner and outer walls. Even if this part could be made by traditional methods, which is doubtful, 3D printing made it faster and cheaper. NASA has also tested a rocket engine turbopump made with Powder Bed Fusion. The 3D printed design is more complex than its traditionally made counterpart, with almost half as many parts, and could not even be made by traditional methods.

Because of the difficulty and expense of launching equipment into space, 3D printers may eventually

be used to manufacture spacecraft in space. NASA's SpiderFab project will employ robots to assemble spacecraft components 3D printed in space.

NASA is not alone in using 3D printing for space travel. Elon Musk's SpaceX used Powder Bed Fusion to 3D print its SuperDraco thruster, which powers its Dragon spacecraft. According to Musk, "through 3D printing, robust and high-performing engine parts can be created at a fraction of the cost and time of traditional manufacturing methods. SpaceX is pushing the boundaries of what additive manufacturing can do in the 21st century."

Mars and Moons

With its eye on a Mars mission, NASA issued a design challenge that resulted in a new 3D printing process called "selective separation sintering," which is intended to combine gravel found on Mars with magnesium oxide (also found on Mars) and 3D print things like bricks and tiles capable of withstanding the heat and pressure of a spacecraft's engines. Deep Space Industries has a similar plan: using robots to mine asteroids and feed the mined raw materials to 3D printers, which will make more robots, mining equipment, and spacecraft to push humans deeper into the cosmos. One cannot help wondering why The Martian's screenwriters didn't give Matt Damon such a 3D printer.

Knowing that people will need cool wheels on other planets just as they do on Earth, Audi, the German car maker, and a team called Part Time Scientist 3D printed the unmanned Lunar Quattro rover from titanium and aluminum. Its first assignment may be to visit the Lunar Roving Vehicle, which NASA left on the moon over 40 years ago. To explore parts of moons and planets that rovers can't reach, NASA is also designing 3D printed drones called Extreme Access Flyers that hover over rough terrain and collect samples.

Some Space is Closer to Home

Not every 3D printed part will help humans to explore space. A piston 3D printed by Aerojet Rocketdyne in 2014 will help launch small spacecraft, such as satellites, into earth orbit. To meet U.S. requirements for a reliable on-demand satellite launch system, the Lawrence Livermore National Lab is 3D printing complete rocket engines, no assembly required. The lab printed the prototype in 8 days for \$10,000, which was much faster and much less expensive than traditional methods.

Other Countries are Helping Humans to Boldly Go

Advances in 3D printing for space exploration are coming from around the world. In 2015, England's University of Birmingham 3D printed a complex, high-performance ceramic rocket engine thruster, at a fraction of the cost of making such a part with traditional methods. New Zealand's Rocket Lab 3D printed its Rutherford rocket engine, named after native son Ernest Rutherford, a Nobel Prize-winning physicist. Using Powder Bed Fusion, Rocket Lab printed the engine's thrust chamber, injector, turbopumps, and main propellant valves, using titanium alloys. Some of these parts could not be made by traditional methods and were 3D printed in days rather than months. The European Space Agency 3D printed a platinum rocket engine combustion chamber and spacecraft thruster nozzle. The parts performed at least as well as their traditionally made counterparts, at greatly reduced cost.

Kids are the Key to Reaching for the Stars

As humans push beyond Earth, innovators will be just as important as 3D printers, if not more so. Tomorrow's innovators are kids today. Kids are just starting to use simple, inexpensive, consumer-grade 3D printers. Kids will not only grow up with 3D printing technology, the technology will grow up with the kids because they will contribute to its advancement. They will learn by using their own machines, teaching themselves, and improving the machines as they go. But they will also need access to advanced machines, processes, and materials. Schools and governments are beginning to pave the roads that kids will follow, from printing toys at home today to making high-tech parts and products in the factories of tomorrow. Today's young innovators will 3D print our future and push us to the stars.

ABOUT THE AUTHOR

NaSPA Member, John Hornick has been a counselor and litigator in the Washington, D.C. office of the Finnegan IP law firm for over 30 years. He is the author of the new book, 3D Printing Will Rock the World, and advises clients about how 3D printing may affect their businesses, frequently writes about 3D printing, and has lectured about 3D printing all over the world.



Survey: 90 Percent of IT Professionals Say They Must Detect Cybersecurity Incidents That May Lead To Breach Within One Day

Current Industry Metrics Don't Align With This Need; Real-Time Network Visibility Is Lacking

Somerset, NJ - May 31, 2016 – Lumeta Corporation, the leader in network situational awareness, today released the findings of a survey that targeted 5,000 U.S. IT executives responsible for network security and network management of large enterprise networks. The research revealed that, in terms of cybersecurity breach detection, there is a large disconnect between IT professionals' needs and today's realities. The overwhelming majority (90%) of IT professionals indicated they want to detect cybersecurity incidents that lead to breaches of their network within a day, 7% said less than one week would be an acceptable timeframe, 3% said less than one month. However, industry data shows the average duration of a breach is more than six (6) months.

Over 60% of respondents believe they are notified of the presence of rogue assets or activity on their network within 10 minutes. Despite this view, industry breach data again tells a different story. According to the Mandiant 2015 Threat Report, only 31% of companies detected breaches on their own, using internal resources. Others learned they were compromised from a third party, such as a supplier, customer or law enforcement.

"As industry data refutes some of the key statements made by respondents, I fear they may be falsely confident that their security program is adequately protecting their information assets," said Reggie Best, chief marketing officer of Lumeta.

The research further revealed that 63% are particularly concerned about threats emanating from mobile, virtual and cloud assets – assets intermittently present in the network. Nearly two-thirds (65%) of IT professionals have difficulty identifying cyber threats fast enough from those transitory assets.

Nearly one-half of respondents say there are key impediments to attaining network visibility: 48 percent said the lack of comprehensive security intelligence available across the network, while 49 percent of respondents cited their inability to monitor every device on the network, particularly mobile or cloud instances.

"With these key impediments to network visibility, they don't know what they are missing on their networks. It's of little wonder that two-thirds of survey respondents are concerned that their companies are experiencing an undetected attack right now," continued Best. "To combat malicious activity on their networks, organizations must incorporate capabilities to comprehensively understand all that is connected to their network, and have a real-time view of new assets as they join the network."

The "Current Trends in Enterprise IT Network Security" survey of U.S. IT executives was conducted by independent research firm LTM Research on behalf of Lumeta.

About Lumeta

Lumeta's network situational awareness platform is the authoritative source for enterprise network infrastructure and cybersecurity analytics. Available for both real-time monitoring and point-in-time auditing, Lumeta recursively indexes a network to identify and map every IP connected device, as well as uncover network segmentation violations and cybersecurity anomalies. For cybersecurity breach prevention and detection, threat intelligence is made actionable by utilizing the Lumeta platform to correlate a comprehensive index of IP address space against known threats. The foundational intelligence provided by Lumeta complements and optimizes existing network and security product investments by feeding them accurate, comprehensive network intelligence. Headquartered in Somerset, New Jersey, Lumeta has operations and clients throughout the world. More information is available at www.lumeta.com

For more information, please visit: go.lumeta.com/visibility

Lumeta, the Lumeta logo, IPsonar and the IPsonar logo are trademarks and service marks of the Lumeta Corporation. Other product and company names appearing in this document may be trademarks of their respective owners.

Melody Iffland
Lumeta Corporation
+1-732-357-3509
miffland@lumeta.com



P.O. Box 398
WOODLAND PARK, CO 80866
PHONE: 719-686-8810
PHONE: 877-417-6830

Three Misconceptions about RAIDs

By Mike Cobb, Director of Engineering

After performing tens of thousands of RAID data recoveries, the team at DriveSavers has seen our share of RAIDs. We've also heard our fair share of theories — some accurate and others, not so much. When it comes to RAIDs, here are three common myths and misunderstandings.

#1: RAIDs are Backups

Although RAID 5, RAID 6 and mirrored systems typically have redundancy built in, which serves to help lessen the risk of losing data when a drive fails physically, these devices most certainly are NOT backups. If too many drives fail, the RAID gets corrupted, a user accidentally erases files or a malicious program takes control and encrypts the contents, your data could be lost.

It's a terrible assumption to make, but oftentimes users see RAID and assume they're protected. Most of the RAID systems we've seen over the years have had redundancies built in. However, these RAID systems have still had multiple failures, data corruption, targeted deletion of data or accidental deletion of data.

When purchasing a complete RAID system, it's good to remember that all of the drives that make up that RAID system are usually the same make, model and age. Identical drives tend to have very similar, or even identical, life spans. Don't forget that while one failed drive may not cause you to lose data, multiple failed drives certainly will.

#2: All RAIDs are Redundant

Despite the word "redundancy" being the first letter of RAID (redundant array of independent disks), not all RAIDs actually have redundancy incorporated.

Consider a RAID 0 setup, which involves "striping" data across 2 or more drives so that different pieces of a single file live on every drive in the system. RAID 0 does not include copies of the data and, therefore, is not redundant. In this case, if just one drive experiences a physical failure, no matter how many drives are incorporated into this setup, the whole RAID is immediately inaccessible and data is lost. In fact, the chances of losing data are actually

multiplied when using a RAID 0 as opposed to a single drive because of this. The more drives used in this setup, the more likely the chance of data loss.

So why would anyone use a RAID 0? The answer is performance. Files are always split into pieces, whether you are using a single drive or a RAID. When pieces of a file are spread across multiple drives, they can be pulled from all of those drives at once rather than just from one drive. To paint a picture, pretend you have two halves of an apple. You will be able to grab the whole apple faster with two hands than with one. This is because you can grab both halves at the same time when using two hands, but only one half at a time when using one hand. In much the same way, the more drives used in your RAID 0 the greater the data transfer rate (the rate at which data moves from one place to another). Just make sure you're backing it all up.

#3: RAID Failure is Always Obvious

Redundancy is one of the two biggest reasons users choose to use RAIDs, the other being performance. If a single drive fails in a RAID with parity or redundancy in place, the system will continue to run in degraded mode at lower performance speed. Since users have access to all of their data, even in degraded mode, they may not notice that anything has changed. In this case, they will carry on, happily unaware, until the next drive fails.

A dedicated system administrator, who regularly and systematically checks a RAID for any problems or concerns, may be able to recognize when one of the drives has failed and replace it before any further failures occur. However, don't forget — the drives in a RAID are often all the same make, model and age with the same life span and likelihood of failure.

The truth is that even RAIDs need to be backed up. As the end user or system administrator, you need to consider the risk of not having an hour-, day-, week-, month- or year's worth of data and plan accordingly. If the data loss would be too devastating for a specific time period, then look for a solution to copy data to another media. That media could be another RAID, the cloud or tape — anything that will ensure that the data is protected when your RAID either fails or has another data loss situation.

ABOUT THE AUTHOR

NaSPA Member, Mike Cobb is the Director of Engineering and manages the day-to-day operations of the Engineering Department including the physical and logical recoveries of rotational media, SSDs, smart devices and flash media. He also oversees the R&D efforts for past, present and future storage technologies. Mike makes sure that each of the departments and their engineers are certified and that they continue to gain knowledge in their field. Each DriveSavers engineer has been trained by Mike to ensure the successful and complete recovery of data is their top priority. Mike Cobb has a B.S. degree in Computer Science from the University of California, Riverside. Since joining DriveSavers in 1994, Mike has worked on all aspects of engineering as well as heading the Customer Service Department for several years. Prior to joining DriveSavers, Mike gained invaluable experience creating mirroring and compression products while working at Golden Triangle Software in the early 1990's.



Like Us on Facebook

www.facebook.com/naspa.online/



Visit the NaSPA Page on LinkedIn

www.linkedin.com/groups/1666



**COMPETITIVE PRICING + ACCOUNT MANAGERS
WHO WORK WITH YOU TO FIND THE
BEST SOLUTION---**

**WWW.SERVERRACKOPTIONS.COM
800-458-6255**

SERVER RACKS - STANDARD - CUSTOM

**PDU'S - KVM SWITCHES - PORTABLE A/C
RACKMOUNT KEYBOARD MONITORS
AND MUCH MORE!**

**SEE OUR NEW AUTO-LOCK C13 POWER
CORDS & JUMPERS**



Tolerance of downtime is
lower than ever before.
Do you have what it takes
to survive an unplanned
interruption?

We can help.



Rentsys[®]
RECOVERY SERVICES

866.915.6000
rentsys.com

Envisioning the Future of Moore's Law, More Than Moore & Beyond Moore for Global Semiconductor Industry - Part II

By Apek Mulay

In Part I of this article, we analyzed all the information provided by ITRS for driving the growth of the semiconductor industry for next 15 years that shall be the roadmap for the semiconductor industry. Having Analyzed all the information presented by ITRS for More than Moore and Beyond Moore, I would like to re-iterate that the ITRS has failed to provide any solution to the diminishing consumer demand in the global economy in spite of acknowledging the fact that multi-faceted public consumer has become an influential driver of the semiconductor industry because of an ever increasing demand of custom functionality in commercial electronic products. Additionally, ITRS has not taken into consideration the Macroeconomics of the semiconductor manufacturing business in proposing its business model for 2020 and beyond. In addition to it, ITRS also falls short in providing any explanation about how to go about measuring the contribution made by the different drivers towards the growth of semiconductor industry roadmap. In Part II, we shall cover how progress of Moore's Law can be sustained with a good Macroeconomic Policy. We shall envision the ideas for More than Moore and Beyond Moore in Part III of this article.

In my two volumes viz. *Mass Capitalism : A Blueprint for Economic Revival (2014)* and *Sustaining Moore's Law: Uncertainty Leading to a Certainty of IoT Revolution (2015)*, I have proposed an innovative business model for the global semiconductor industry that addresses all the questions left unanswered by the ITRS. In fact, this three tier-business model would ensure a long term sustainability and profitability of the semiconductor business while sustaining the continued progress of Moore's Law as well as to usher Internet of Things (IoT) Revolution. The advantage of the proposed new business model is that it takes the merits of both Integrated Device Manufacturer (IDM) and Fabless-Foundry Business models and rectifies their flaws from a macroeconomic perspective.

As this article deals with the top-down hierarchy of the semiconductor industry, we shall consider the benefits of my proposed three-tier business model proposed for only semiconductor industry in order to address those questions left unanswered by the ITRS. Here, We are not going to discuss the three tier business model for ushering Internet of Things (IoT) revolution as discussed in my 2015 volume. We shall also learn about how the proposed new drivers for Moore's Law can fit into this new business model thereby envisioning the contribution of each ITRS driver towards the progress of semiconductor industry. While the IDM business model was helped create more domestic manufacturing jobs domestically and protected

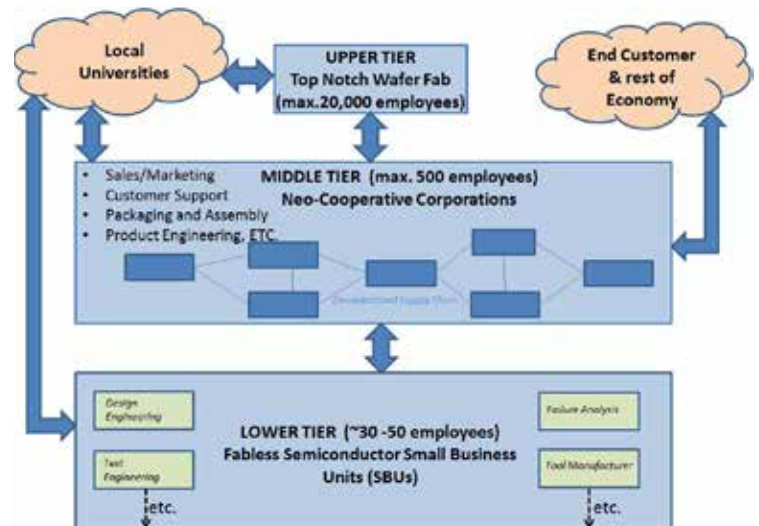

Figure 2-1: A Three-tier business Model for Global Semiconductor Industry. Source: *Mass Capitalism: A Blueprint for Economic Revival*.

the Intellectual Property (IP), the Fabless-Foundry business model led to the creation of several small businesses. The Fabless revolution has over the years enabled creation of small design facilities, test facilities and failure analysis laboratories, etc. Additionally, there has been a greater collaboration between the design and manufacturing teams for the fabless-foundry business model. However, Fabless business model ignored the macroeconomic policies which resulted in increasing trade and budget deficits. Fabless-foundry business model also led to the problem of counterfeit electronics entering into the supply chains of developed economies where Government

Accountability Office (GAO) estimated that approximately 40% of US DoD (Department of Defense) supply chain is filled with defective or counterfeit goods.. In order to ensure profitability of any project, a proper macroeconomic policy is essential because only a good macroeconomic policy ensures the health of macroeconomy. A proper macroeconomic policy ushers healthy growth of both supply and demand, which acts as an engine for economic growth.

The Supply of goods comes from the productivity of the workforce and the demand comes from their wages. A free market economic policy that ensures a steady growth in supply and demand should adopt a policy such that wages of workforce keeps track with their productivity. Such a policy ensures that there exists a sustainable demand for manufactured goods in order to ensure their consumption. Only when there is a healthy demand of manufactured goods, do more investments come into the economy in order to get a good Return on Investments (RoI). Semiconductor manufacturing being a very capital intensive business, the business model for the industry should be both sustainable and profitable in spite of continuous ever-increasing capital investments that are needed for driving the progress of Moore's Law. Additionally, the macroeconomic policies should usher

Only when there is a healthy demand of manufactured goods, do more investments come into the economy in order to get a good Return on Investments (RoI).

a competitive Capitalism or free markets that benefit not only the producers but also end consumers. In that regard, having a domestic fabless-foundry business model is more advantageous for an economy as long as all fabless businesses get their manufacturing done from only domestic foundries thereby eliminating any trade deficits resulting from offshoring of manufacturing, design, assembly, etc. Countries like India which lack IP for semiconductor manufacturing, could license this technology from developed countries in a technologically advanced country until they develop their own IP. Having domestic fabless-foundry business model for every economy is critical in order to reduce their dependence on imported electronics which contributes to trade deficits and eventually causes a devaluation of country's currency.

Every Economy goes through waxing and waning cycles. More detail explanation as well as an impact of these macroeconomic cycles on the semiconductor industry business models has been analyzed in my 2015 volume '*Sustaining Moore's Law*'. In order to have a true free market economy where the role of government is small and intervention of the government into the economy is minimal, having a good business model as well as formulating proper macroeconomic policies is critical. The business model of semiconductor industry should minimize the problem of unemployment during economic downturns. Only then would it be possible to have low income taxes on citizens of a country. If there is a huge unemployment during a downturn, the government has to spend money for the unemployment benefits of laid off workers. In an economic downturn, the government could also give tax incentives to revive the manufacturing sector. But, In either case the budget deficits rise and so does the government spending rise in order to finance those deficits. These policies indirectly hurts the value of currency and calls for new taxes on citizens thereby increasing the size of government. Hence, In order to minimize the size of the government, it is essential to avoid huge unemployment during economic downturns.

Taking this into consideration, an innovative Three-Tier business model has been presented in Figure 2-1 that would not only provide a more collaborative business model but would also minimize the problem of huge unemployment during economic downturns due to the presence of a middle-Industrial tier which interacts directly with the end customer and rest of the economy. Due to the absence of this Middle industrial tier in the economy, there would be no monitoring of slowdown in consumer demand resulting in excess supply and poor demand leading to layoffs in manufacturing and service sectors. Additionally, this business model ensures a much better integration by having a diverse set of products from different design teams giving an added flexibility to the businesses in the middle industrial tier in order to manufacture customized multi-faceted products for customers. There are many more benefits of this business model including getting support from local government in order to keep this capital intensive semiconductor manufacturing business sustainable while still ensuring that there is minimal of government intervention into the economy. More details can be found by the reader in my first volume *Mass Capitalism: A Blueprint for Economic Revival*.

In this way, the presented Three-Tier Business Model would ensure increased top-down industry collaboration driving the growth of overall semiconductor industry. Another advantage of this model is being able to benefit

the overall economy by means of transitioning to ever increasing diameter of silicon wafers thereby increasing the profitability for the manufacturers as well as reducing the costs of products for end consumers. In fact, 450 mm transition is a huge step that could be adopted by the global semiconductor industry in order to come out of ongoing economic stagnation and the proposed Three-Tier business model will help the semiconductor industry in this transition by ensuring a good Return on Investments (RoI) through continuous growth in demand.

REFERENCES

1. Mulay, Apek. 2015. *Sustaining Moore's Law: Uncertainty Leading to a Certainty of IoT Revolution*. Morgan & Claypool, San Ramon, CA.
2. Mulay, Apek. 2014. *Mass Capitalism: A Blueprint for Economic Revival*. Book Publishers Network, Bothell, WA.

ABOUT THE AUTHOR

NaSPA Member, Apek Mulay is a Business and Technology Consultant at Mulay's Consultancy Services. He is also a senior analyst and macroeconomist in US Semiconductor Industry. He is author of book *Mass Capitalism: A Blueprint for Economic Revival*. Mulay has also authored another book *Sustaining Moore's Law: Uncertainty Leading to a Certainty of IoT Revolution* with Morgan & Claypool publishers. He pursued undergraduate studies in Electronics Engineering (EE) at the University of Mumbai in India and has completed master's degree in EE at Texas Tech University, Lubbock. Mulay authored a patent "Surface Imaging with Materials Identified by Colors" during his employment in Advanced CMOS technology development team at Texas Instruments Inc. He has also chaired technical sessions at International Symposium for Testing and Failure Analysis (ISTFA) for consecutive years. USCIS approved his US permanent residency under the category of foreign nationals with extraordinary abilities in science and technologies even though he did not pursue a PhD degree in engineering or economics. He has been cited as an 'Engineer-cum-Economist' by superstar economist Professor Ravi Batra in his 2015 Volume 'End Unemployment Now: How to Eliminate Poverty, Debt and Joblessness despite Congress'. He has appeared on National Radio shows, made Cover Story for Industry Magazines, authors articles for newspapers as well as several reputed blogs & industry publications, as well as has been invited on several Television shows (because of his accurate macroeconomic forecasts) for his ideas about Mass Capitalism. He is also an investing partner in an ecommerce business *Calcuttahandicraft*.in which he started to envision his ideas about Mass Capitalism. www.ApekMulay.com



Book Review Highlights -

1. "offers hope for embattled US economy"- Dr. Stanley Wolf
2. "an intriguing solution for semiconductor industry" - Dr. Kris Iniewski
3. "quite extra-ordinary" - Peter Gasperini
4. "Interesting and readable presentation of collaborative economics"- Dr. Stephen Willis
5. "excellent documented proposal for semiconductor industry"- Dr. Douglas Miller
6. "A wave of the future" - Dr. Ravi Batra
7. "Informed and informative, thoughtful and thought-provoking" - Midwest Book Review

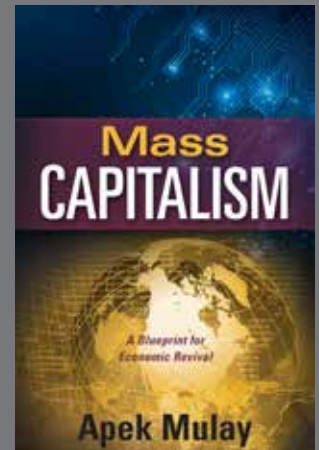

HORIZON

CISCO Gold Partner

EXPAND YOUR CURRENT TECHNOLOGY INTO THE CLOUD
ON PREMISES | OFF PREMISES

YOUR TOTAL CLOUD SOLUTION

For more information, please visit www.knightpoint.com.
We look forward to connecting with you.

KNIGHT POINT
S Y S T E M S

Auerbach Publications
The Final Word in Enterprise Computing and Networking

Always be smarter than the people who hire you.

~ Lena Horne



**The Hottest Technology Jobs In the Country Are On the NaSPA Job Site
Open Your Job Seeker Account TODAY. It's Free.**

www.Careers.NaSPA.com

The mission of NaSPA, a non-profit corporation, is to advance the technical management and career development abilities of its Members.

NaSPA fosters a greater respect for network, mainframe, information technology, telecommunications, business continuity, and other professions, while it improves employment prospects and educational opportunities for thousands of practitioners worldwide.

Inspiring advancement of technology professions since 1986

 **NaSPA**
Network and Systems Professionals Association

Consider a Corporate Membership in NaSPA

What are the benefits for the NaSPA Corporate Member? In a word, the benefits can be extraordinary:

- Liberal Use of Email Communications and Magazine Ads
- NaSPA Web Banners That Identify You as an Elite NaSPA Corporate Member
- Press Releases and New Product Announcements to Our Members
- Feature Articles in Technical Support Magazine by Your Employees
- Press Releases, Employment, and Recruitment Ads on Our Website
- Up to Ten Complimentary NaSPA Memberships
- Access to a 30-year old NaSPA Software Library and Repository
- Direct Access to NaSPA policymakers
- Access to NaSPA Social Media Such as Our **Linked in**. Site
- Discounts on Booth Space at the NaSTEC Convention
- The Instant Credibility and Worldwide Exposure That Comes From Working With One of America's Oldest Technology Organizations

Learn More, Call Us at 888/215-0997!

Consider the many benefits of associating with one of the most trusted names in Information Technology. Won't you please consider a Corporate Membership in NaSPA?

Visit www.NaSPA.com for details.

Well Done!

But Don't Stop Here



Get Involved!

Membership in the Network and Systems Professionals Association is FREE for Students and Faculty*

- *Technical Support Magazine*
- Expansive On-Line Research Libraries
- Job Placement and Hiring Site
- Discounts on Technical Books and Publications
- FREE NaSPA Thrift Benefits Prescription Card
- Other Discounts on Services You Use Every Day!

Get Published!

Call for Original Articles and Technical Papers

NaSPA has provided award winning publications like [Technical Support Magazine](#) to professionals worldwide since 1986. Whether you are a student or faculty member, we invite you to submit a 1000-1500 word article or research paper for publication. The topic must be germane to IT, mainframe, data center, telecommunications, cloud applications, systems programming, or other relevant topics. NaSPA members are given extra consideration in final acceptance. Submit your article or research paper to editor@naspa.online and take that first step in making a name for yourself through NaSPA's award-winning publications.

Join Today!



NaSPA

Network and Systems Professionals Association

Contribute Today!

NaSPA Student Opportunities

* Limited Time offer, some restrictions apply. © 2016 Network and Systems Professionals Association, Inc. www.naspa.com.

NaSPA Memories



*This month the NaSPA
Time Machine takes us back
20 years to June 1996...*



A MILESTONE:

NASPA CELEBRATES ITS

10th

ANNIVERSARY

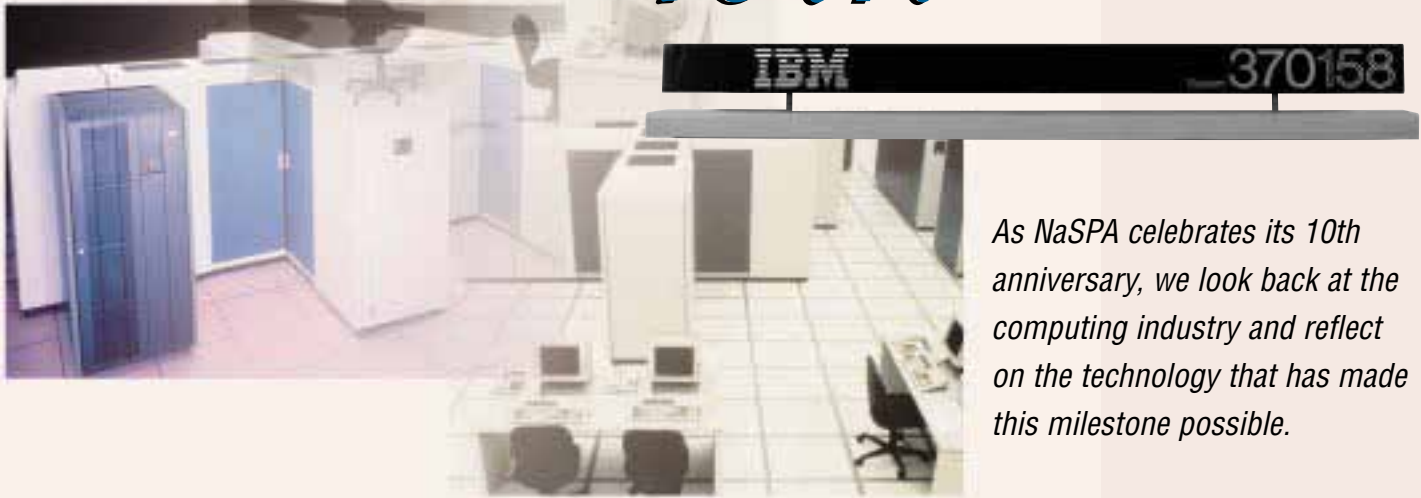

As NaSPA celebrates its 10th anniversary, we look back at the computing industry and reflect on the technology that has made this milestone possible.

NaSPA, *The Association for Corporate Computing Technical Professionals*, was founded in 1986 by Scott Sherer, a former DP professional for a major industrial conglomerate. NaSPA serves as the primary information source for systems professionals worldwide.

ACTIONS SPEAK LOUDER THAN WORDS

In 1986, there were only a handful of organizations that catered to the needs of systems professionals, and these organizations only touched the surface when it came to providing comprehensive services. NaSPA was created to fill the void.

"My vision for NaSPA came from the visible lack of support organizations available in the DP environment. As a DP professional, I longed for technical information, educational opportunities, and networking opportunities. My colleagues felt the same way; they were looking for a support organization. NaSPA fulfilled that desire for thousands of DP professionals worldwide."

CHANGING TIMES

NaSPA originally stood for the National Systems Programmers Association. But with distributed computing came changes to the roles of support personnel; support functions were not limited to only systems programmers, but all IS professionals. Thus, the *association for corporate computing technical professionals* was born. Today, the pendulum is swinging back to mainframe-centric computing. This renaissance is due largely to the numerous system attributes of MVS that, to date, and despite marketing hype, have not been delivered by other platforms.



Not unlike the computing industry, NaSPA has changed over the years to meet the needs of its members. *Technical Support* magazine was first published in January 1987. The first issue, which featured "Mr. Mainframe" on the cover, summed up the state of the industry at that time: The mainframe was the predominant computing force.

Today, the mainframe continues to serve as the primary computing resource for a significant percentage of our members' companies. While we've seen some divestiture toward network interconnectivity, the fact remains that the mainframe is the most bullet-proof platform.

MEMBERSHIP HAS ITS BENEFITS

Since its inception, NaSPA has grown to include 45,000 members from the United States and 80 countries. These individuals represent all facets of business: banking and finance, education, consulting, industrial, government, healthcare, insurance, etc.

To fulfill the specific requirements for this diverse global audience, NaSPA provides several career-enhancing benefits:

Technical Support Magazine: Shifting Focus

Technical Support magazine, the most visible benefit of NaSPA membership, provides information our members need to optimize their systems and advance their careers. *Technical Support* strives to provide articles written by "real users" who describe in detail the techniques and shortcuts they used to make their systems more productive. To help members make enlightened purchasing decisions, *Technical Support* also provides articles that examine the technology behind the products and their problem/solution capabilities.

Charles Mills, president of Firesign Computer Company, developers of OUTBOUND, an unattended file transfer product, is an avid reader and contributor to *Technical Support*. Mills, who wrote the article, "Host-Initiated File Transfer With Unattended PCs," in October 1989, feels that the magazine helped launch his product. Mills who was not involved in the 370 world from 1977 to 1987, credits

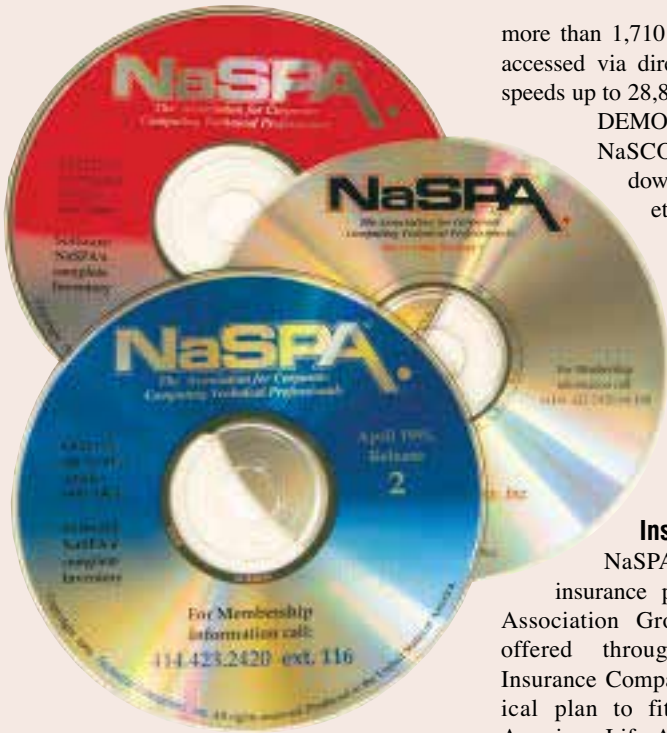

more than 1,710 games. These CDs may be accessed via direct dial [(414) 768-8002 at speeds up to 28,800 bps] or via Telnet.

DEMOS on DEMAND, a service of NaSCOM, allows members to download and evaluate proprietary software from leading software companies such as PKZIP MVS (Ascent Solutions, Inc.), DBtoolkit (Softworks), and MVS/Quick-Ref for Windows (Chicago-Soft, Ltd.). Telnet or FTP access is available (see page 40 for more information).

Insurance Assurance

NaSPA offers several types of insurance plans to its members: The Association Group Major Medical Plan, offered through Washington National Insurance Company, provides a major medical plan to fit everyone's needs. North American Life Assurance Company offers a comprehensive package including term life, hospital income, and personal accident insurance. For more information, contact International Benefit Services Corporation at (800) 759-0101.

NaSPA works with PROinsure to provide profession-specific errors and omissions liability insurance. For more information, please contact Debbie Zarecki at (800) 899-1399.

the magazine with helping to "reconnect" him to the 370 world. "OUTBOUND was [Firesign's] first 370 project in 10 years; it was the start of our growth. *Technical Support* helped us get OUTBOUND off the ground. Our first break was an article in one of the weeklies; the second was the article I wrote for *Technical Support*. *Technical Support* magazine is different from its competition; it's the only technical publication in the 370/390 marketplace," Mills says.

NaSCOM: Keeping You Connected

NaSPA's bulletin board system, NaSCOM, which is interconnected to the Internet, serves as a communications conduit for NaSPA members. In addition to providing members with the opportunity to share ideas and solutions through email, NaSCOM provides forums on a number of topics, ranging from MVS, VM, and VSE to politics and StarTrek. These forums, both Internet and NaSPA-specific, allow members to participate in "discussions" on numerous topics. Check out our home page at <http://www.nascom.com/> which contains up-to-the-minute information on NaSPA's services and member benefits. In addition, the NaSPA home page is "hotlinked" to numerous vendor home pages (see page 40 for more information).

NaSCOM also provides members the opportunity to view and download the contents of 24 CD-ROMs which are available on the system. These CDs include the NaSPA CD Version 2, which contains the NaSPA MVS VIP and CBT tapes and *Technical Support* magazine (1987-1994), Windows NT shareware, and GIGA Games 3, a collection of



MCI: Keeping Your Company Connected

NaSPA member's employers may be eligible to receive discounts through a program that offers a wide range of long distance services, including OUTBOUND, 800, data, international, video conferencing, calling cards, and 800 service, as well as advanced billing and management reports to meet the needs of any size member business. For more information, call (800) 288-7524.



Job Placement: Bell & Associates

Bell & Associates is linked to a nationwide network of more than 200 offices nationwide to provide career assistance for both permanent and temporary/contract assignments. Bell & Associates can be reached on the Internet at <http://www.staffing.net/bell.htm>. or at (800) 488-5627.

"I predict that we will see more connectivity, overall capacity and facility improvement — it's not going to slow down."

*Dwight S. Miller
NaSPA member since 1987*

Career Advancement

NaSPA can also help advance your career through training courses provided by numerous education vendors. NaSPA has arranged discounts with these vendors who offer a variety of education services and training for systems professionals (see page 70 for more information).

NASPA: A TECHNICAL KNOWLEDGE BASE

According to Greg Price, of Melbourne, Australia, one of the greatest benefits NaSPA membership provides is a great resource of knowledge. "NaSPA has direct access to probably the greatest collection of public domain software for MVS (maybe the mainframe as a whole) in the world. Couple this with the up-to-date techo talk available in *Technical Support* and there is a lot of material to support the sysprog in his/her endeavours." Price, who is a senior systems programmer for Ferntree Computer Corporation, has been a NaSPA member since 1990.

NETWORKING OPPORTUNITIES

In addition to the multitude of benefits, for many members, "human interaction" is an important part of being a NaSPA member.

Rick Fochtman, a senior systems programming specialist for the Board of Trade Clearing Corporation, Chicago, has 27 years of experience in computing. Fochtman, who has been a NaSPA member since 1990 contributed File 147 — The Archiver, the systems programmer's toolkit manager — to the CBT Tape.

How we Got From There: 10 YEARS OF EVOLUTION

Viewpoints From the NaSPA Board of Directors

As a NaSPA member, Fochtman has had countless opportunities to network with fellow members. "I've made some very good friends and received a lot of help when I've been in a jam," he said. "The networking is worth its weight in gold."

Dwight S. Miller, a NaSPA member since 1987, echoes Fochtman's sentiments on the value of NaSPA as a networking conduit. "The sharing of information is invaluable. I've had access to samples and help with problem solving." Miller likens the membership to a "human database" — a collection of human intelligence and skills. Miller works for IIX (Insurance Information Exchange), a division of AMS Services, Inc., part of an insurance consortium, in Bryan, Texas. While he is not a specialist in one particular area, Miller prefers to call himself a "nexialist" — the ultimate non-specialist, which requires both breadth and depth of knowledge. His skills range from MVS systems and applications programming to communications to VAX operations technical supervision and NetWare administration. As a NaSPA member, Miller has participated in active discussions on NaSCOM, presented at NaSTEC, NaSPA's education conference, written several articles for *Technical Support* magazine, and is currently a technical editor for the magazine. Miller received the NaSPA Distinguished Service Award for his involvement in 1990.

WHERE DO WE GO FROM HERE?

What's ahead for the computing industry? Many members predict that there will be less downsizing and more rightsizing. Other members predict that the future of IS will be more of the same: we will continue to see power in the desktop, midrange, and mainframe environments, and the mainframe will participate more as a super server.

According to Miller, "I predict that we will see more connectivity, overall capacity and facility improvement — it's not going to slow down."

As NaSPA celebrates its 10th anniversary, and looks ahead at the future, one thing is certain: It won't slow down either. **ts**

©1996 Network and Systems Professionals Association Reprinted with permission of **Technical Support** magazine.



Emit Hurdelbrink



James "J.D." Drechsler



Thomas Bryant



John Suchodolski



Radi Shourbaji



Scott Sherer



Amy Birschbach

For Emit Hurdelbrink, his career began by accident. While in the Army, he was looking for "something interesting" as he puts it, and applied with another person for a single opening at the computer school for which he was chosen. After leaving the army, he began working for the City and County of Denver as an operator, where is still employed today as a technical support manager.

"NaSPA has allowed me to develop beyond just being an IT professional, Hurdelbrink said. As a board member, I have been able to work with a variety of individuals, crossing platform technology, spanning the world. I have been exposed to a variety of individuals, all of whom I've learned from."

According to James "J.D." Drechsler, who has worked for American Express for more than 25 years, the biggest advancement he's seen in computing in the past 10 years has been in the reliability of the hardware to operate 24x7 and allow recovery of applications and data without major down time.

As editor of *Technical Support* magazine for the past three years, and having worked with the magazine since 1987, Amy Birschbach has viewed the changes in the industry from a vantage point.

"With the PC/networking explosion, the magazine has had to keep pace with all the different hardware/software platforms supported by our members," Birschbach said. "My contact with the board members, authors, columnists, technical editors, and other industry professionals has helped me stay apprised of the industry and keep the readers satisfied."

Tom Bryant who works for Platinum technology, inc., in Oak Brook Terrace, Ill., believes that the PC has revolutionized our business. "Where once mainframe and dumb terminals ruled the land, you now have many varieties of

hardware and software. Flexibility is the key quality to have now," Bryant explained.

Bryant was elected to the NaSPA board of directors in November 1995. He has been involved with NaSPA since 1987, and credits his association involvement with helping him secure his current job. "While giving my MVS diagnostics presentation at NaSTEC 6.0 (1994), I met a product developer at Platinum, and the rest is history," Bryant said.

Bryant, who was named "NaSPA Member of the Year" in 1990 is a frequent contributor to *Technical Support* magazine.

"NaSPA is about people," says NaSPA President, Scott Sherer. "These people are our members, and these members are leading the technology revolution around the world."

Prior to founding NaSPA, Sherer worked for 15 years in applications programming, operations, systems programming, office automation, and tech services management.

Those experiences have served him well in leading NaSPA through many industry changes. "We have come full circle in our industry. We've seen small computers getting larger. Large computers becoming enormous. Large computers being replaced by small computers. Small computers mimicking large computers and finally, all of them working together in a heterogenous network...and being implemented by our members!"

Sherer adds "The next 10 years will see incredible increases in inexpensive communications bandwidth. This bandwidth will inspire businesses to digitize, store, and transmit everything imaginable. The capacity increases in computing will be in orders of magnitude. Our association will have its hands full keeping our members abreast of this. We definitely look forward to serving the NaSPA membership for the next 10 years!"

ENJOY SPECIAL SAVINGS ON THE BOOKS YOU NEED TO



Ensure Agile, Resilient, and Energy-Efficient Networks and Systems

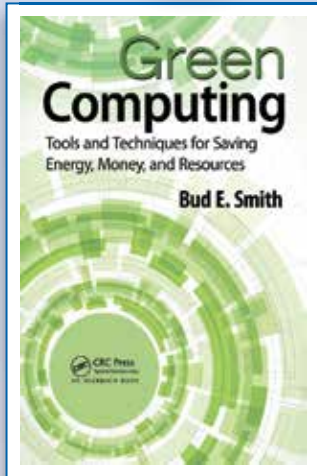

ISBN: 978-1-4665-0340-3

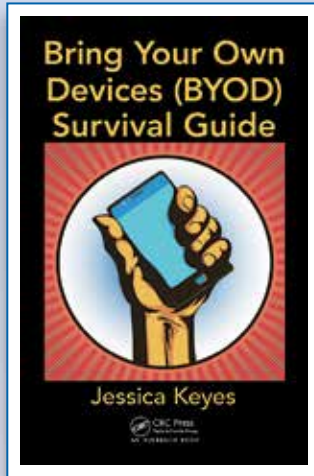

ISBN: 978-1-4665-6503-6

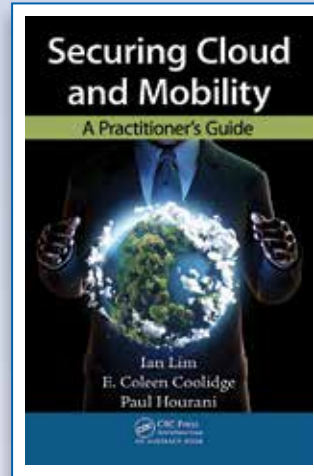

ISBN: 978-1-4398-5055-8

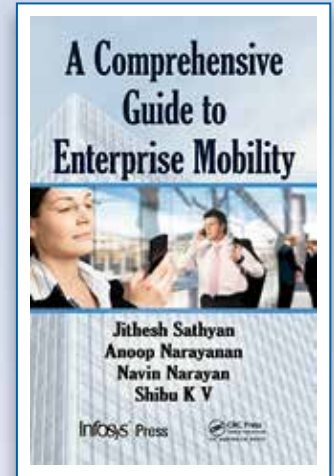

ISBN: 978-1-4398-6735-8

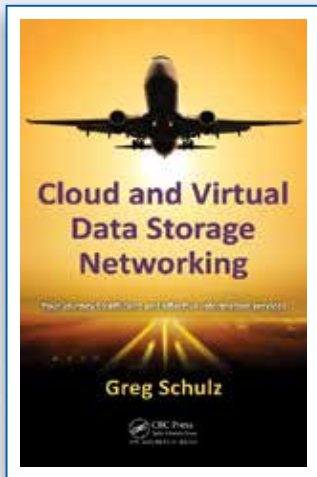

ISBN: 978-1-4398-5173-9

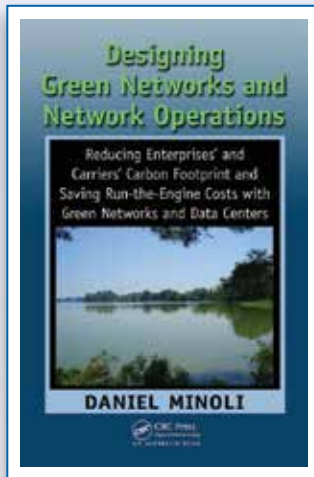

ISBN: 978-1-4398-1638-7

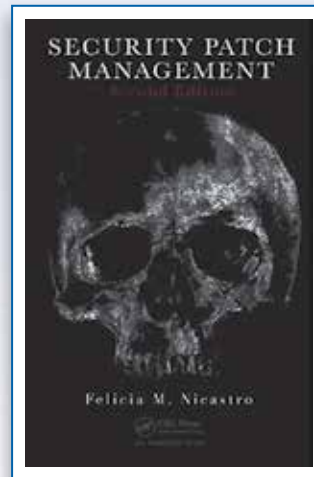

ISBN: 978-1-4398-2499-3



ISBN: 978-1-4398-3487-9

Sign Up for Our Free Newsletters and Connect with CRC Press IT Books on Facebook, Twitter, and LinkedIn to Keep the Discounts Coming!



The final word in information systems security



In-depth... insightful... for today's technology leaders



Improving organizational performance through IT



WWW.CRCPRESS.COM



CRC Press
Taylor & Francis Group

Order online and enter discount code **GWN13** to **SAVE 25%**, plus **FREE Standard Shipping**

Fed Your Job Prospects Lately?



Since 1986, NaSPA (the Network and Systems Professionals Association) has been the premier not for profit advocate to technology and professionals worldwide. For 30 years professionals have coursed through NaSPA training programs, subscribed to its award winning publications, attended its conferences and trade shows, and enjoyed the many other benefits of NaSPA membership. Now you can find one of the most useful EMPLOYMENT SITES in the industry, proudly sponsored by one of the most trusted names in technology.

Nourish Your Organization, or Your Career, with the NaSPA Job Site!

Whether you are looking for the perfect employment candidate, or are an I.T. Professional looking to advance a career, you owe it to yourself to have a look. It's all in one place you can *truly trust*. Visit our EMPLOYMENT SITE at careers.NaSPA.com.



Network and Systems Professionals Association

P.O. BOX 1681 • Red Oak, TX 75154 • 888.215.0997 • www.naspa.com

